

SCALPEL HANDLES

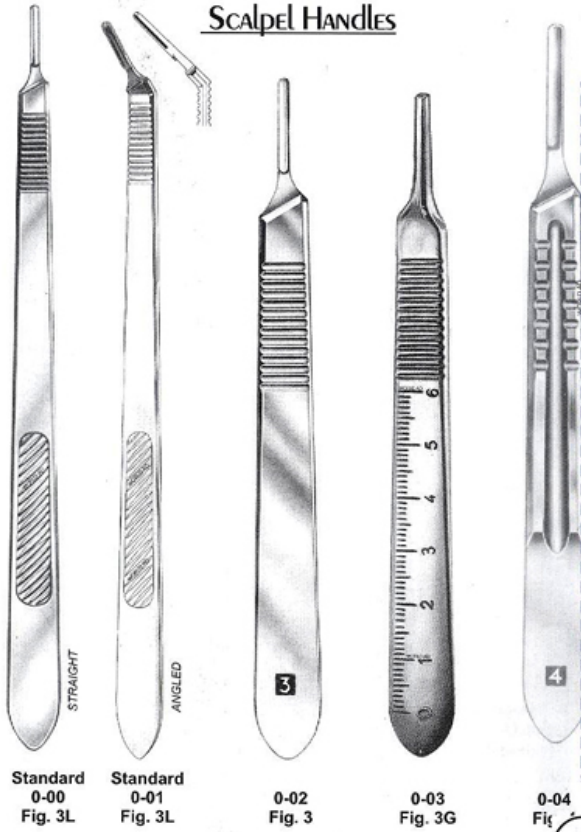

SCALPEL HANDLES



1

DISSECTING KNIVES

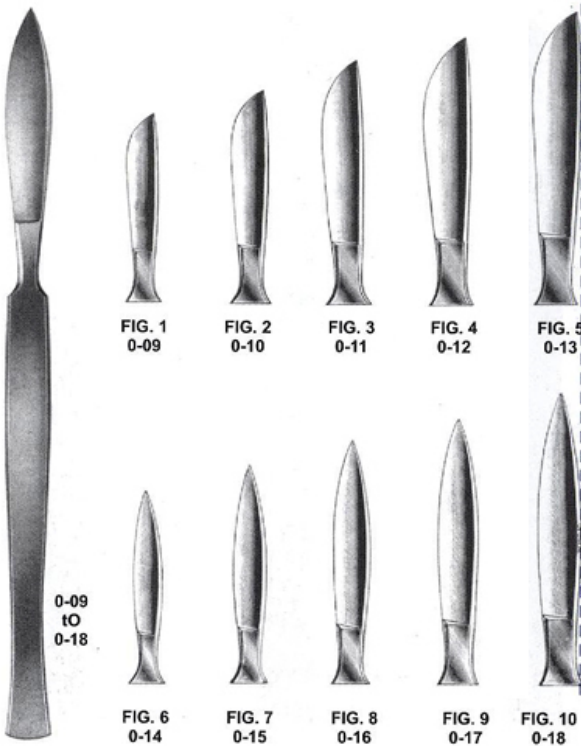

OPERATING, AMPUTATING KNIVES

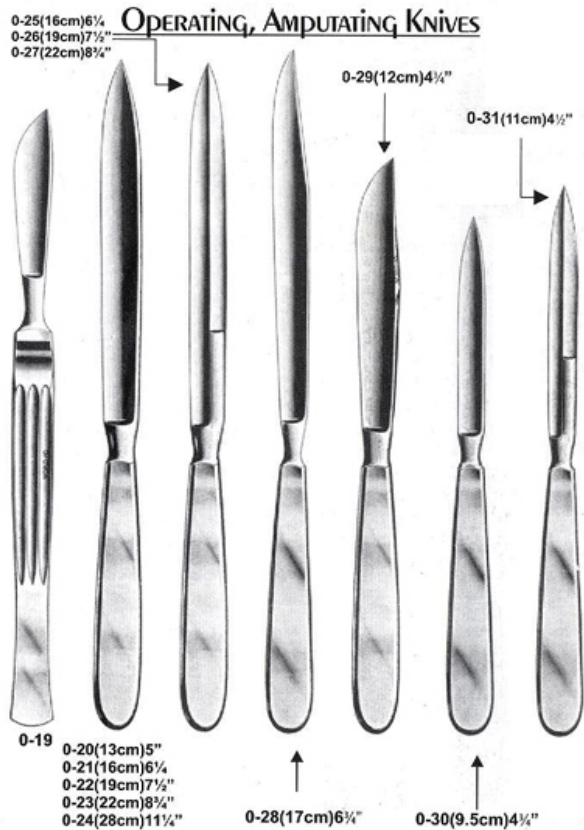

RESECTION KNIVES

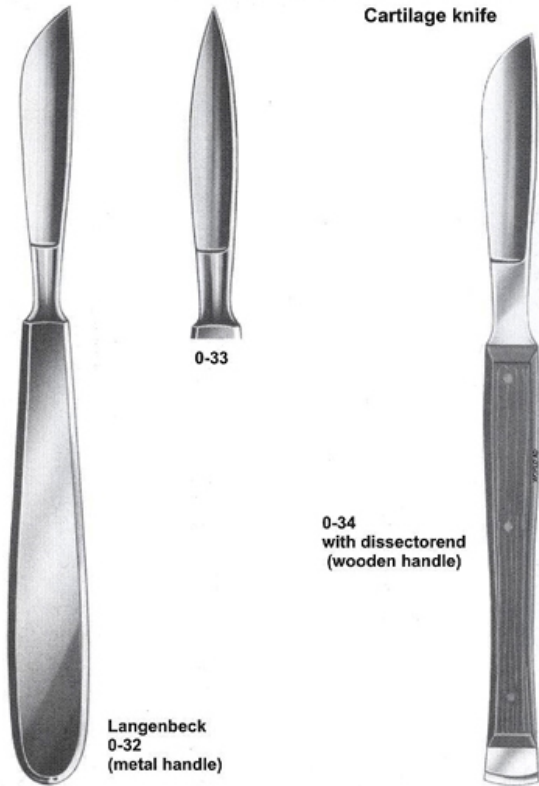

Langenbeck
0-32
(metal handle)

0-33

0-34
with dissector end
(wooden handle)

Cartilage knife

AUTOPSY KNIVES

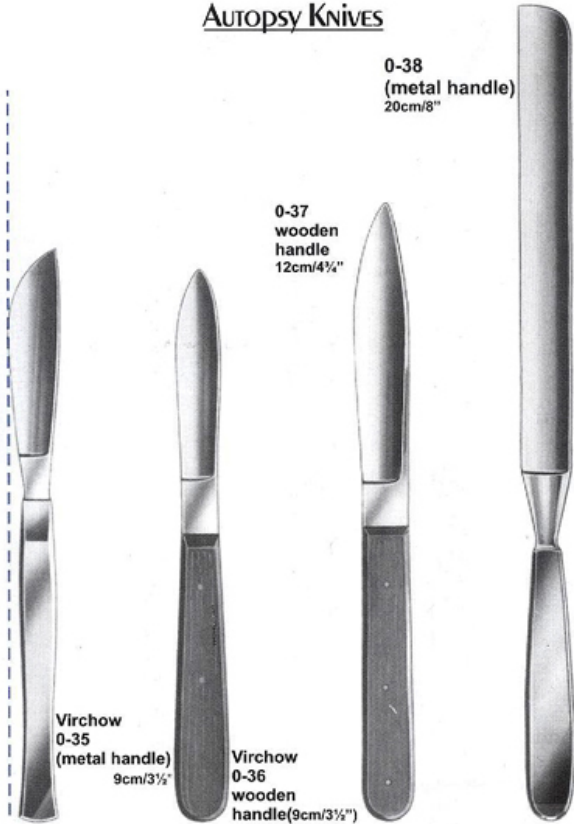

Virchow
0-35
(metal handle)
9cm/3½"

0-37
wooden
handle
12cm/4¾"

Virchow
0-36
wooden
handle(9cm/3½")

0-38
(metal handle)
20cm/8"

2

POST MARTEM & BRAIN KNIFE



Post Martem knife

(wooden handle)
0-39(11cm)4¼"
0-40(17cm)6¾"

Brain knife

Virchow
(metal handle)
0-41(16cm)6¼"
0-42(20cm)8"
0-43(24cm)9½"

DISSECTING KNIVES

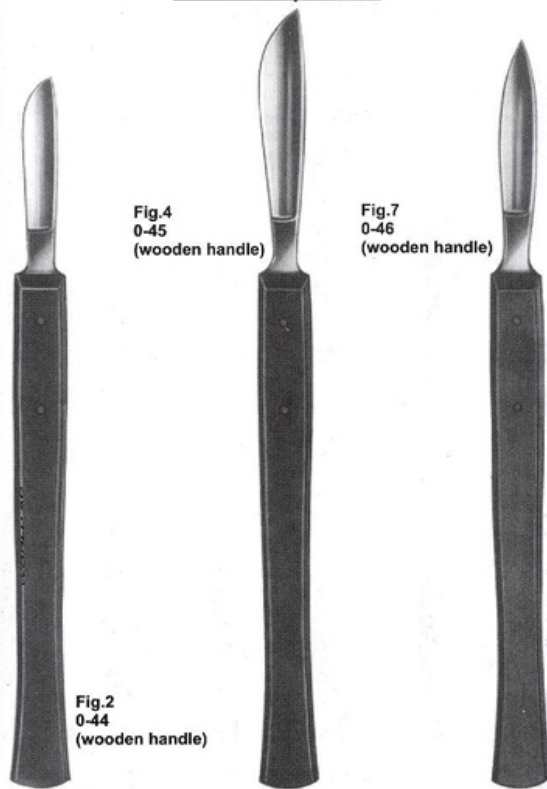
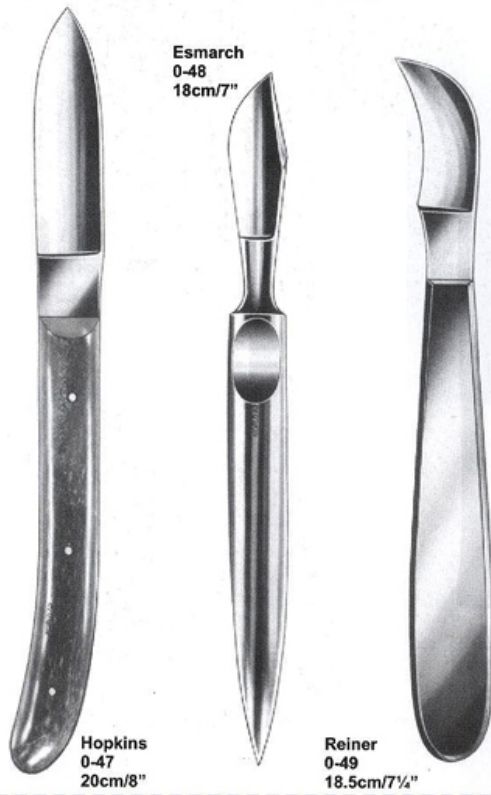

Fig.4
0-45
(wooden handle)

Fig.7
0-46
(wooden handle)

Fig.2
0-44
(wooden handle)

PLASTER-OF-PARIS KNIVES



EYE KNIVES



3

CATARACT, DIACISSION KNIVES, KERATOMES

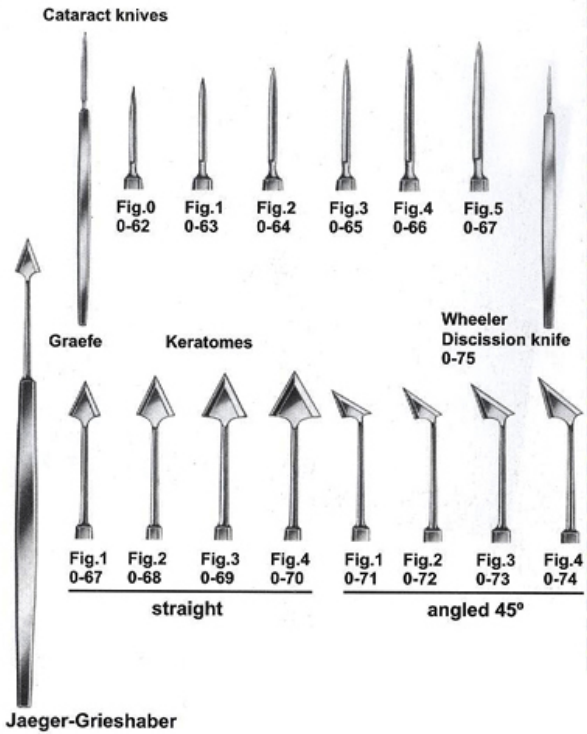

RHINOPLASTIC KNIVES

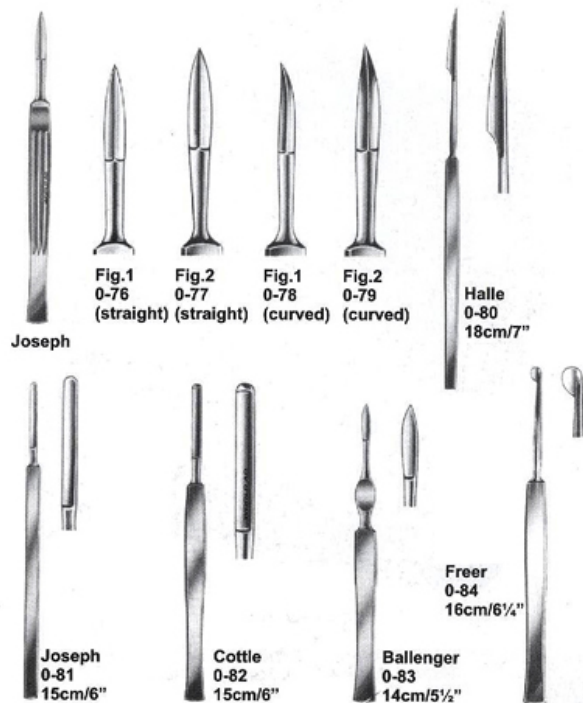

DIAGNOSTICS

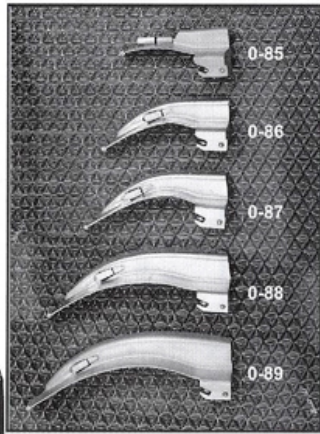

McIntosh



McIntosh
Laryngoscope Set
0-90

DIAGNOSTICS

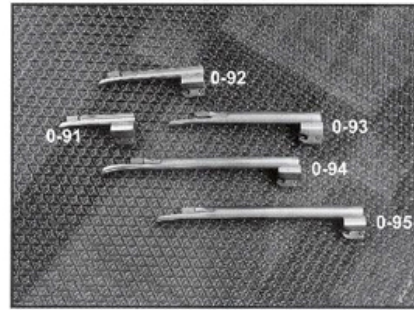

Miller



Miller
0-96
Laryngoscope
set

4

DIAGNOSTICS



Otoscope Set
0-97
Consisting Of Battery Handle
(without Battery) 3 Ear Specula, 1 Bulb

DIAGNOSTICS



Diagnostic Set
(ENT Complete)
0-98
Consisting Of Battery Handle (without Battery)
3 Ear Specula, 1 Nasel Specula,
2 Laryngeal Mirrors With Holder
1 Tongue Depressor Holder, 1 Bulb

Dissecting Sets

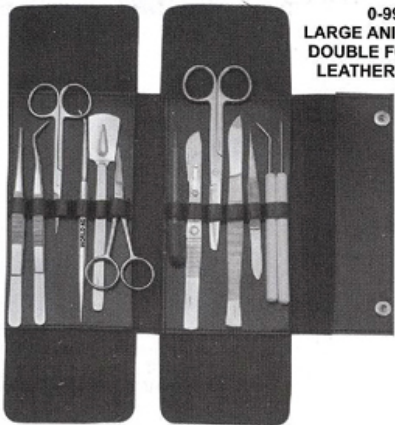

0-99
LARGE ANIMAL SET
DOUBLE FOLDING
LEATHER CASE.

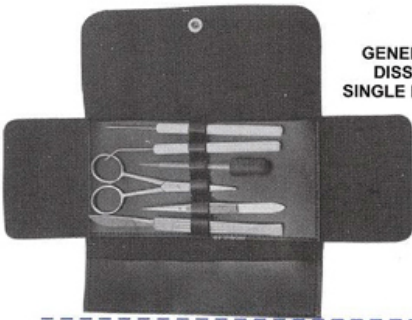

0-100
GENERAL BIOLOGY
DISSECTING SET
SINGLE LEATHER CASE.

Dissecting Sets

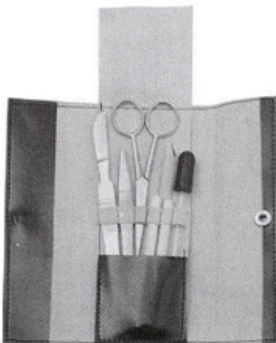

0-103
BASIC DISSECTING SETS
VINYLE POUCH.

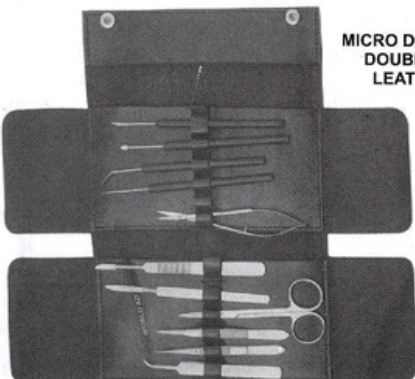

0-104
MICRO DISSECTING SET
DOUBLE FOLDING
LEATHER CASE.

Dissecting Sets

0-101
TISSUE CULTURE
DISSECTING SET
LEATHERETTE CASE.

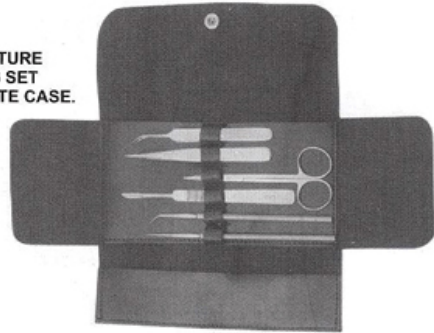

0-102
ANATOMY DISSECTING SET
DOUBLE FOLDING
LEATHER CASE.

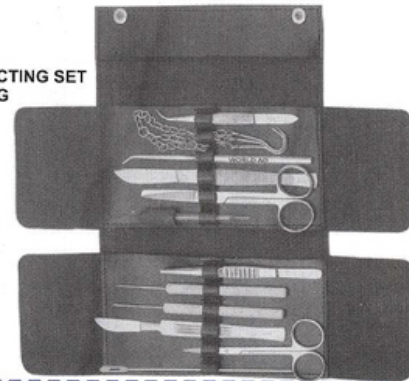

5

Dissecting Sets

0-105
ANATOMY
DISSECTING SET
DOUBLE FOLDING
LEATHER CASE.

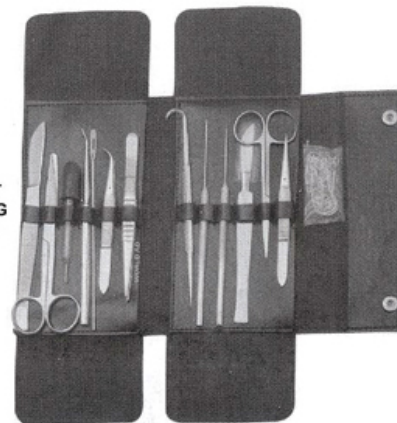

0-106
NEW INSTRUCTOR'S
DISSECTING SET.
ZIPPERED CASE

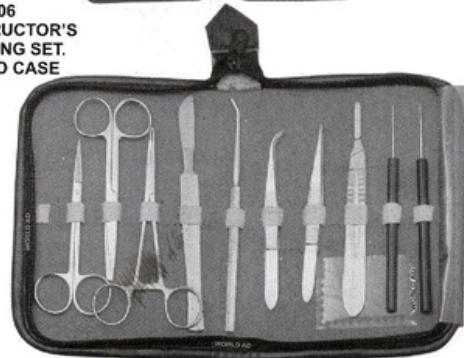

PERCUSSION HAMMERS

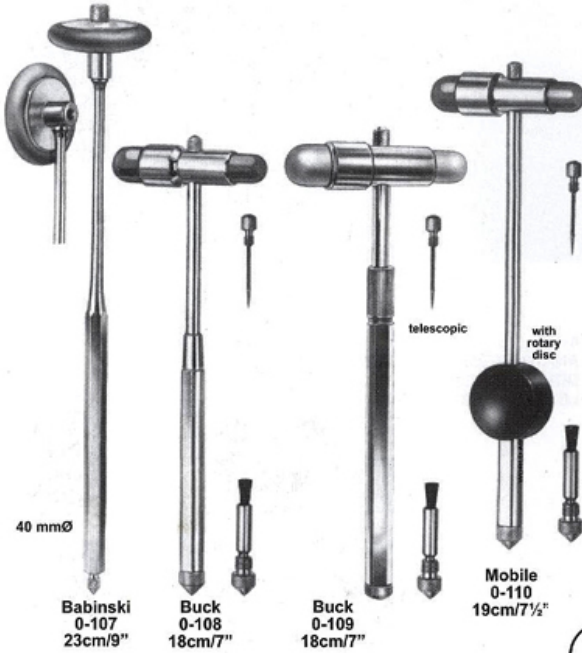

PERCUSSION HAMMERS

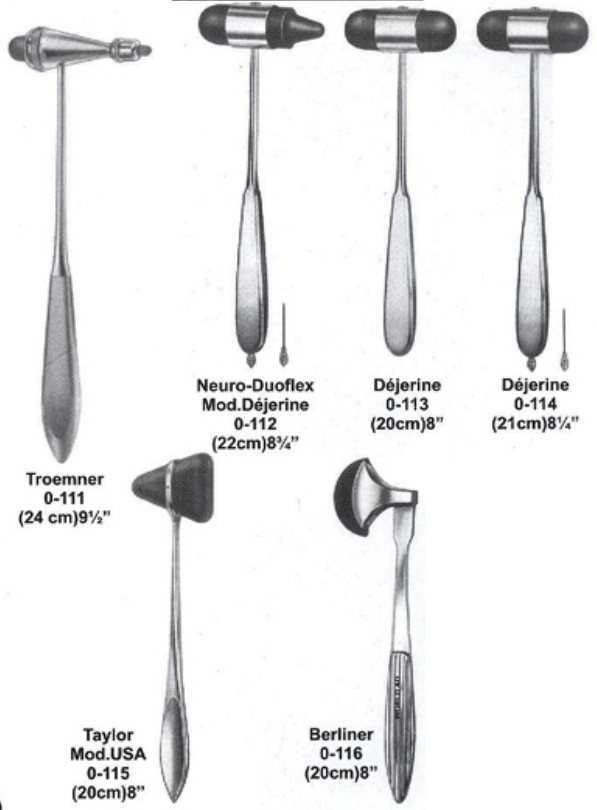

6

SENSIBILITY INSTRUMENTS

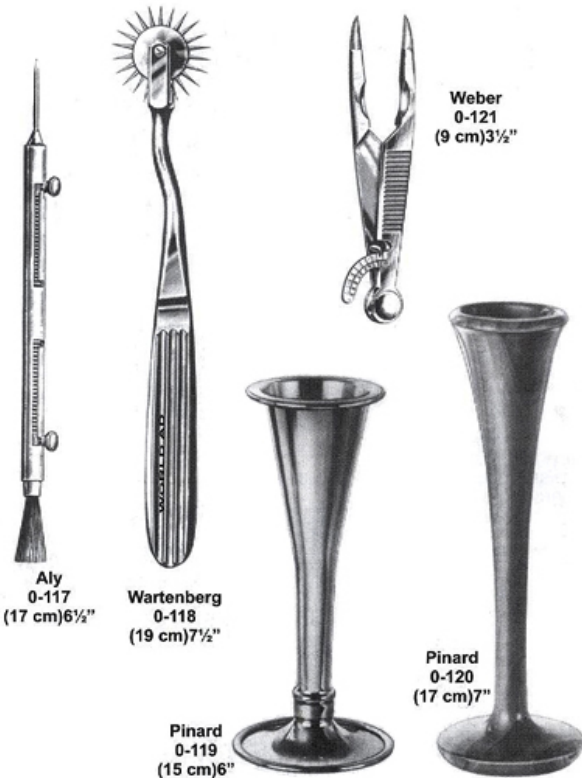

TUNING FORKS

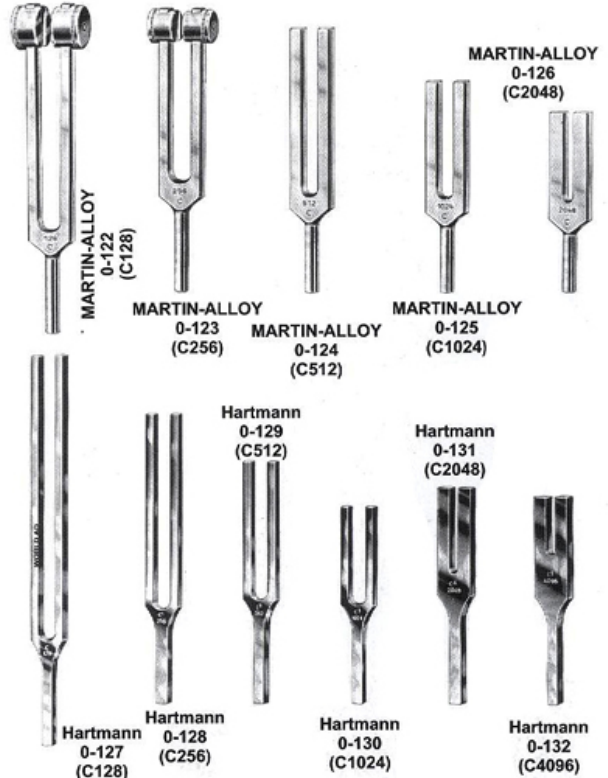

PROBES

PROBES



Stacke
0-133
(10.5cm) 4 1/4"
1 mmØ



0-134(14.5cm) 5 1/2"
0-135(16cm) 6 1/4"
0-136(20cm) 8"



0-137(11.5cm) 4 1/2"
0-138(13cm) 5"
0-139(14.5cm) 5 1/2"
0-140(16cm) 6 1/4"
0-141(18cm) 7"
0-142(20cm) 8"



0-143(13cm) 5"
0-144(14.5cm) 5 1/2"
0-145(16cm) 6 1/4"
0-146(18cm) 7"



Doyen
0-147
(14cm) 5 1/2"
1 mmØ



Nélaton
0-148
(16cm) 6 1/4"
1 mmØ

7

CURETTES

CURETTES & SPOON



Langenbeck
0-149
13cm (5 1/4")



Shapleigh
13cm (5 1/4")



Buck
16.5cm (6 1/2")

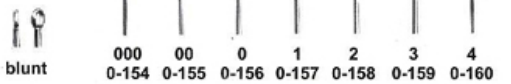

blunt

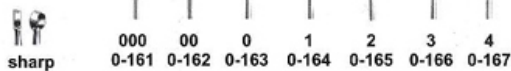

sharp



Buck
16.5cm (6 1/2")

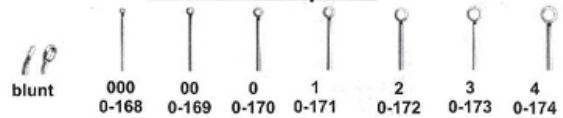

blunt



sharp



Coxeter
0-182
15cm (6")



Mod. Martin
0-183
17cm (6 3/4")



Jansen
0-184
15cm (6")



Barth
0-185
18cm (7 1/4")

SUCTION TUBES

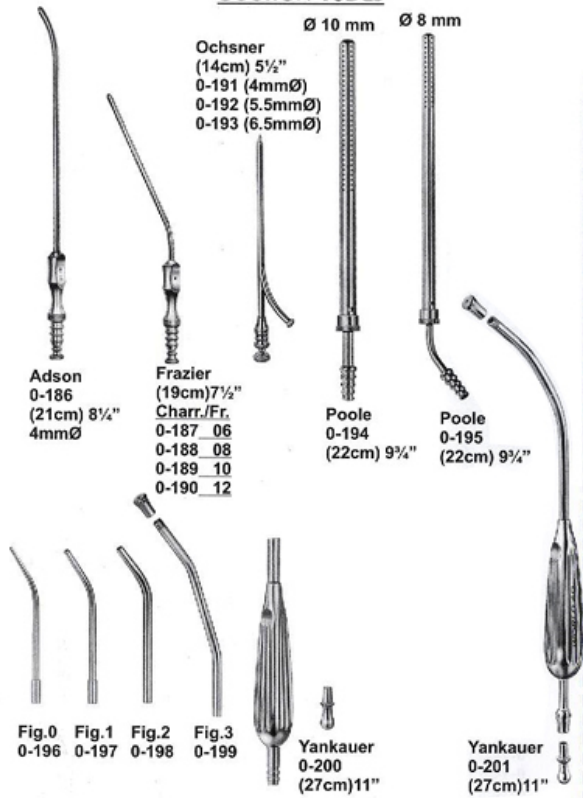

SUCTION TUBES



TRACHEA TUBES



8

CATHETER INTRODUCING FORCEPS

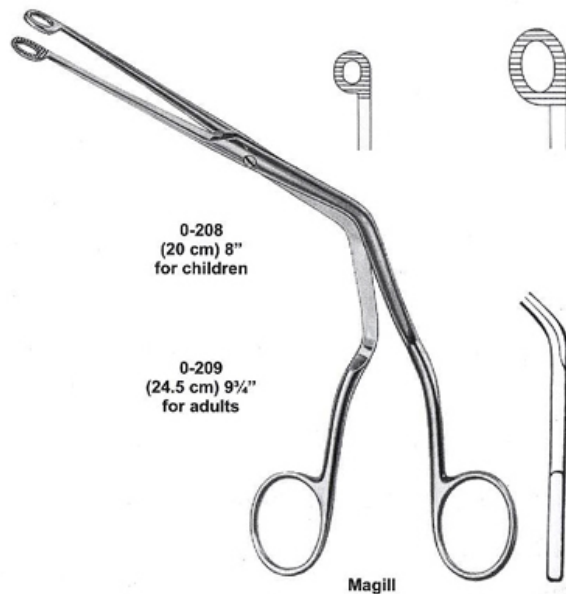

TROCARS

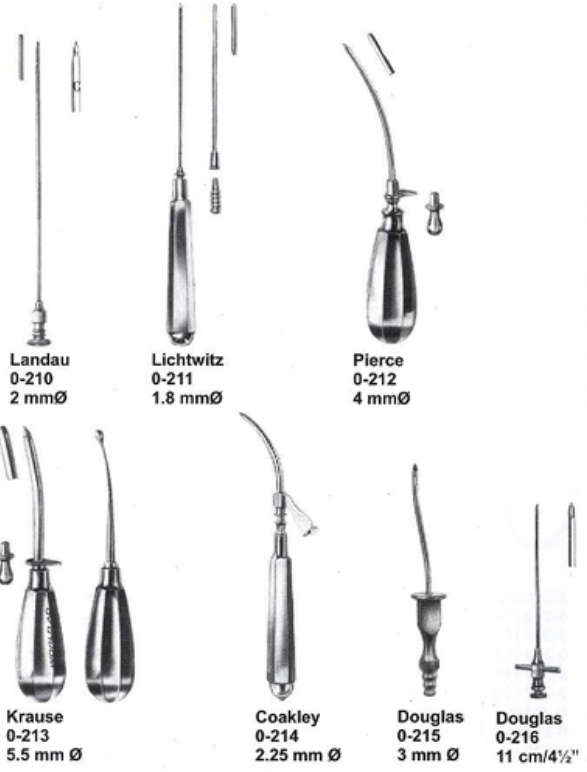

Landau
0-210
2 mmØ

Lichtwitz
0-211
1.8 mmØ

Pierce
0-212
4 mmØ

Krause
0-213
5.5 mm Ø

Coakley
0-214
2.25 mm Ø

Douglas
0-215
3 mm Ø

Douglas
0-216
11 cm/4½"

TROCARS

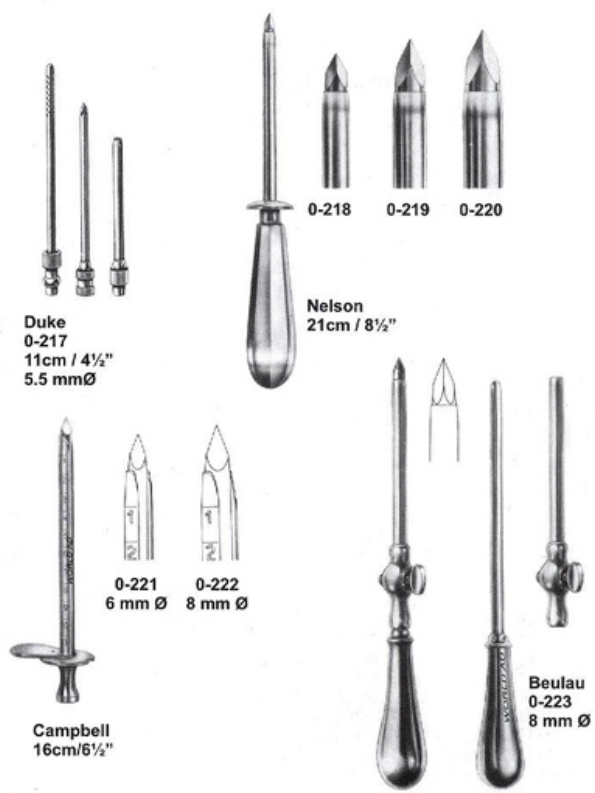

Duke
0-217
11cm / 4½"
5.5 mmØ

Nelson
21cm / 8½"

0-218

0-219

0-220

0-221
6 mm Ø

0-222
8 mm Ø

Campbell
16cm/6½"

Beulau
0-223
8 mm Ø

TROCARS

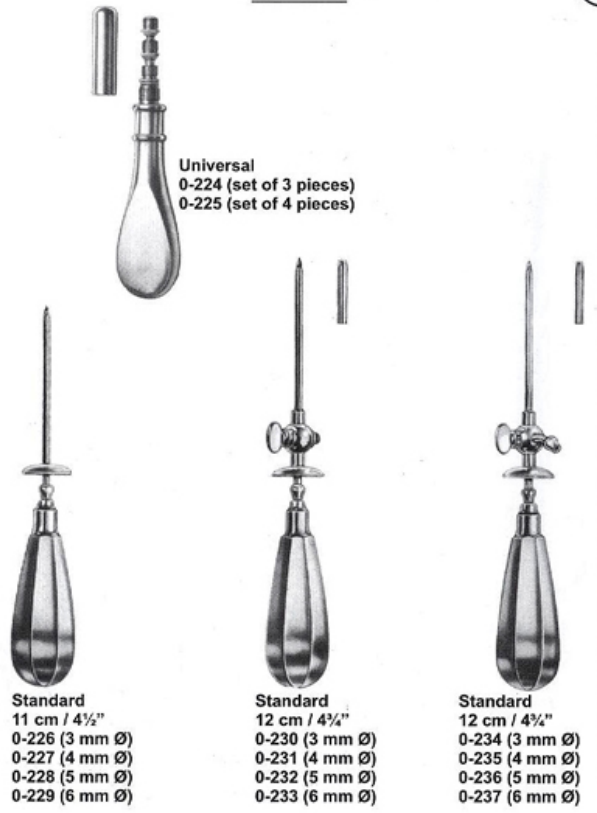

Universal
0-224 (set of 3 pieces)
0-225 (set of 4 pieces)

Standard
11 cm / 4½"
0-226 (3 mm Ø)
0-227 (4 mm Ø)
0-228 (5 mm Ø)
0-229 (6 mm Ø)

Standard
12 cm / 4½"
0-230 (3 mm Ø)
0-231 (4 mm Ø)
0-232 (5 mm Ø)
0-233 (6 mm Ø)

Standard
12 cm / 4½"
0-234 (3 mm Ø)
0-235 (4 mm Ø)
0-236 (5 mm Ø)
0-237 (6 mm Ø)

TROCARS

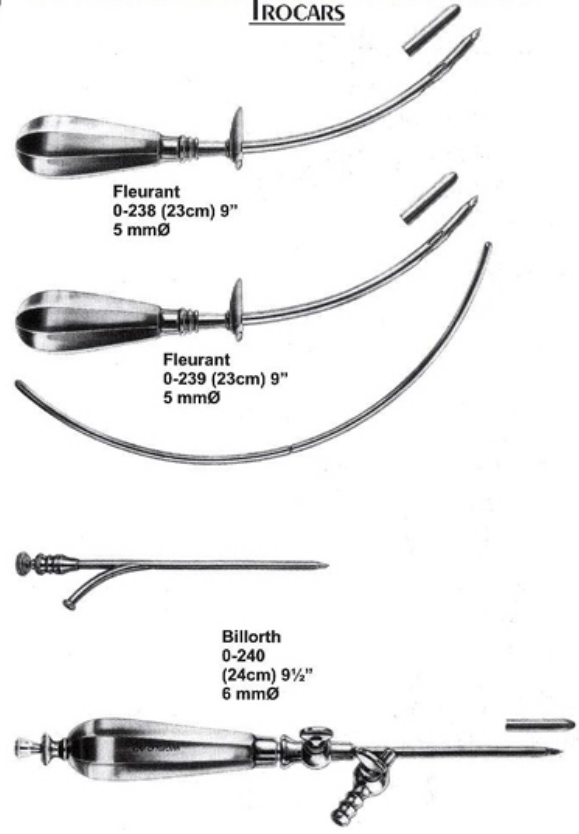

Fleurant
0-238 (23cm) 9"
5 mmØ

Fleurant
0-239 (23cm) 9"
5 mmØ

Billorth
0-240
(24cm) 9½"
6 mmØ

OPERATING SCISSORS

Straight



Straight



Straight

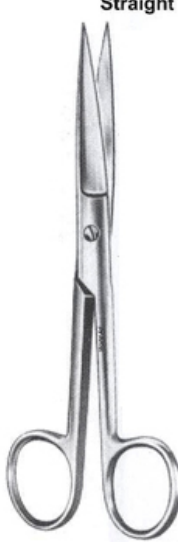

STANDARD
 0-241 (10.5cm) 4¼" "
 0-242 (11.5cm) 4½" "
 0-243 (13...cm) 05" "
 0-244 (14.5cm) 5¼" "
 0-245 (15.5cm) 06" "
 0-246 (16.5cm) 6½" "
 0-247 (17.5cm) 07" "
 0-248 (18.5cm) 7¼" "
 0-249 (20cm...) 08" "

STANDARD
 0-250 (10.5cm) 4¼" "
 0-251 (11.5cm) 4½" "
 0-252 (13 cm) 05" "
 0-253 (14.5cm) 5¼" "
 0-254 (15.5cm) 06" "
 0-255 (16.5cm) 6½" "
 0-256 (17.5cm) 07" "
 0-257 (18.5cm) 7¼" "
 0-258 (20 cm) 08" "

STANDARD
 0-259 (10.5cm) 4¼" "
 0-260 (11.5cm) 4½" "
 0-261 (13...cm) 05" "
 0-262 (14.5cm) 5¼" "
 0-263 (15.5cm) 06" "
 0-264 (16.5cm) 6½" "
 0-265 (17.5cm) 07" "
 0-266 (18.5cm) 7¼" "
 0-267 (20cm...) 08" "

OPERATING SCISSORS

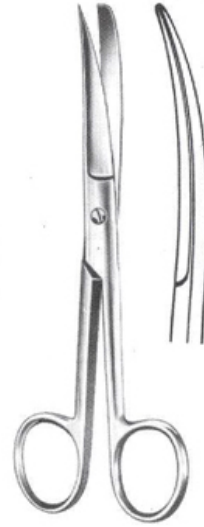

STANDARD
 0-268 (10.5cm) 4¼" "
 0-269 (11.5cm) 4½" "
 0-270 (13...cm) 05" "
 0-271 (14.5cm) 5¼" "
 0-272 (15.5cm) 06" "
 0-273 (16.5cm) 6½" "
 0-274 (17.5cm) 07" "
 0-275 (18.5cm) 7¼" "
 0-276 (20cm...) 08" "

STANDARD
 0-277 (10.5cm) 4¼" "
 0-278 (11.5cm) 4½" "
 0-279 (13...cm) 05" "
 0-280 (14.5cm) 5¼" "
 0-281 (15.5cm) 06" "
 0-282 (16.5cm) 6½" "
 0-283 (17.5cm) 07" "
 0-284 (18.5cm) 7¼" "
 0-285 (20cm...) 08" "

STANDARD
 0-286 (10.5cm) 4¼" "
 0-287 (11.5cm) 4½" "
 0-288 (13...cm) 05" "
 0-289 (14.5cm) 5¼" "
 0-290 (15.5cm) 06" "
 0-291 (16.5cm) 6½" "
 0-292 (17.5cm) 07" "
 0-293 (18.5cm) 7¼" "
 0-294 (20cm...) 08" "

10

OPERATING SCISSORS



Incision Scissor
 0-295 (13cm) 05" "
 0-296 (14.5cm) 5¼" "



Deaver straight
 0-297 (14cm) 5½" "



Deaver curved
 0-298 (14cm) 5½" "



Mayo-Still straight
 0-299 (15cm) 06" "
 0-300 (17cm) 6¾" "
 0-301 (19cm) 7½" "



Mayo-Still curved
 0-302 (15cm) 06" "
 0-303 (17cm) 6¾" "
 0-304 (19cm) 7½" "



Mayo (straight)
 0-305 (14.5cm) 5¼" "
 0-306 (15cm) 06" "
 0-307 (17cm) 6¾" "
 0-308 (23cm) 09" "



Mayo (curved)
 0-309 (15cm) 06" "
 0-310 (17cm) 6¾" "
 0-311 (19cm) 7½" "
 0-312 (19cm) 7½" "

OPERATING SCISSORS

Gynecological Scissor

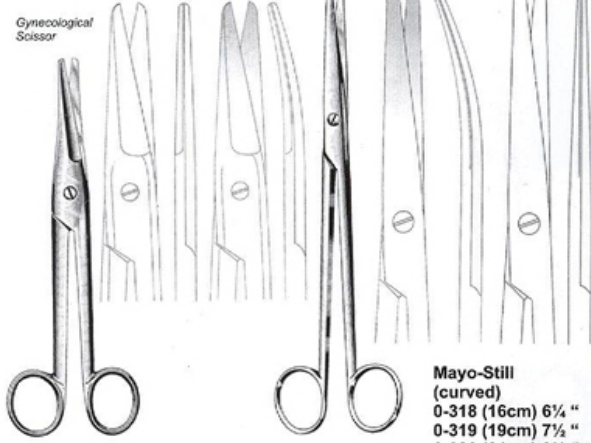

Mayo-Noble (straight)
0-313 (17cm) 6¼ inch
(curved)
0-314 (17cm) 6¼ inch

Mayo-Still (straight)
0-315 (16cm) 6¼ "
0-316 (19cm) 7½ "
0-317 (21cm) 8¼ "

Mayo-Still (curved)
0-318 (16cm) 6¼ "
0-319 (19cm) 7½ "
0-320 (21cm) 8¼ "

OPERATING SCISSORS



Wertheim (curved)
0-321 (14cm) 5½ "
0-322 (19cm) 7½ "
0-323 (22cm) 8¾ "

Mayo-Harrington (straight)
0-324 (22cm) 8¾ "
(curved)
0-325 (22cm) 8¾ "
0-326 (30cm) 12 "

11

DISECTING SCISSORS

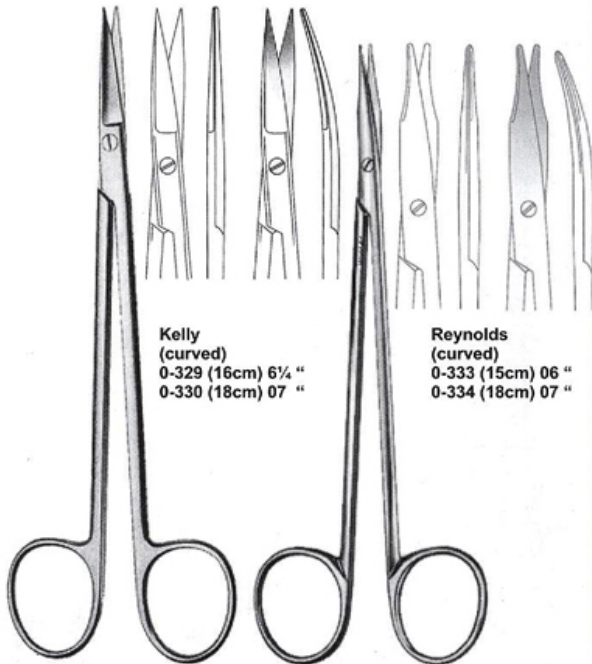

Kelly (curved)
0-329 (16cm) 6¼ "
0-330 (18cm) 07 "

Reynolds (curved)
0-333 (15cm) 06 "
0-334 (18cm) 07 "

Kelly (straight)
0-327 (16cm) 6¼ "
0-328 (18cm) 07 "

Reynolds (straight)
0-331 (15cm) 06 "
0-332 (18cm) 07 "

DISECTING SCISSORS



Metzenbaum (straight)
0-335 (14.5cm) 5¾ "

Metzenbaum-Delikat (straight)
0-337 (14.5cm) 5¾ "

Metzenbaum (curved)
0-336 (14.5cm) 5¾ "

Metzenbaum-Delikat (curved)
0-338 (14.5cm) 5¾ "

DISECTING SCISSORS

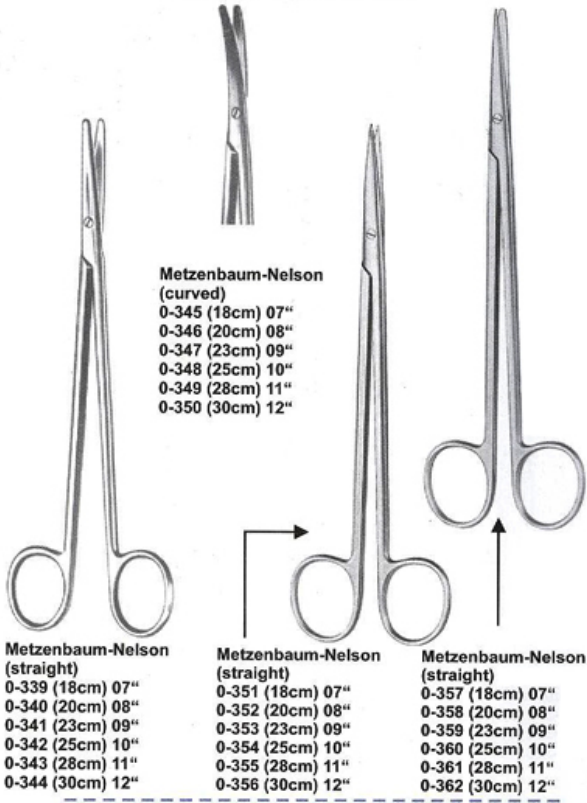

Metzenbaum-Nelson (curved)
 0-345 (18cm) 07"
 0-346 (20cm) 08"
 0-347 (23cm) 09"
 0-348 (25cm) 10"
 0-349 (28cm) 11"
 0-350 (30cm) 12"

Metzenbaum-Nelson (straight)
 0-339 (18cm) 07"
 0-340 (20cm) 08"
 0-341 (23cm) 09"
 0-342 (25cm) 10"
 0-343 (28cm) 11"
 0-344 (30cm) 12"

Metzenbaum-Nelson (straight)
 0-351 (18cm) 07"
 0-352 (20cm) 08"
 0-353 (23cm) 09"
 0-354 (25cm) 10"
 0-355 (28cm) 11"
 0-356 (30cm) 12"

Metzenbaum-Nelson (straight)
 0-357 (18cm) 07"
 0-358 (20cm) 08"
 0-359 (23cm) 09"
 0-360 (25cm) 10"
 0-361 (28cm) 11"
 0-362 (30cm) 12"

OPERATING SCISSORS

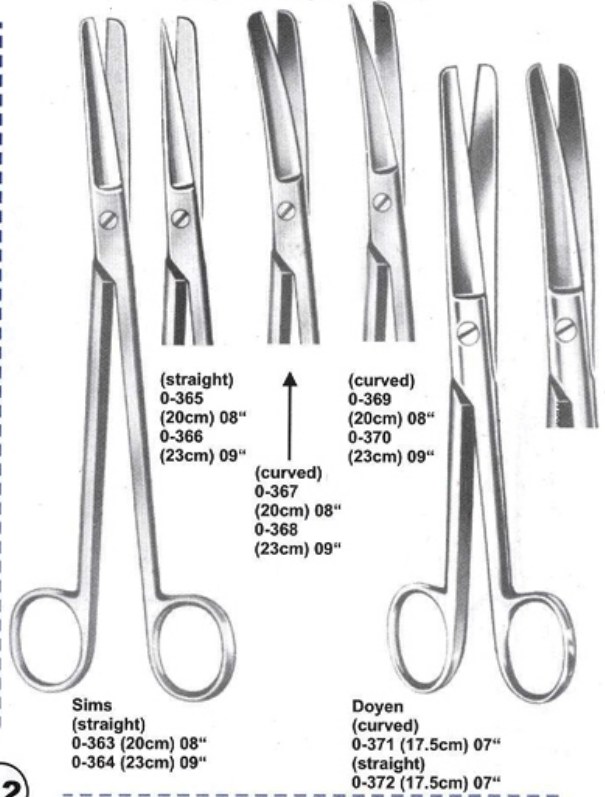

(straight)
 0-365 (20cm) 08"
 0-366 (23cm) 09"

(curved)
 0-367 (20cm) 08"
 0-368 (23cm) 09"

(curved)
 0-369 (20cm) 08"
 0-370 (23cm) 09"

Sims (straight)
 0-363 (20cm) 08"
 0-364 (23cm) 09"

Doyen (curved)
 0-371 (17.5cm) 07"
 (straight)
 0-372 (17.5cm) 07"

NEUROSURGICAL SCISSORS



Toennis
 0-373 (18cm) 07"
 (straight)
 0-374 (18cm) 07"
 (curved)

Toennis-Adson
 0-375 (17.5cm) 07"

Olivercrona
 0-376 (23cm) 09"

NASAL SCISSORS



Joseph (straight)
 0-377 (14cm) 5 1/2"
 (curved)
 0-378 (14cm) 5 1/2"

Kilner (curved)
 0-379 (12.5cm) 05"

Heymann (curved)
 0-380 (18cm) 07"

EYE SCISSORS

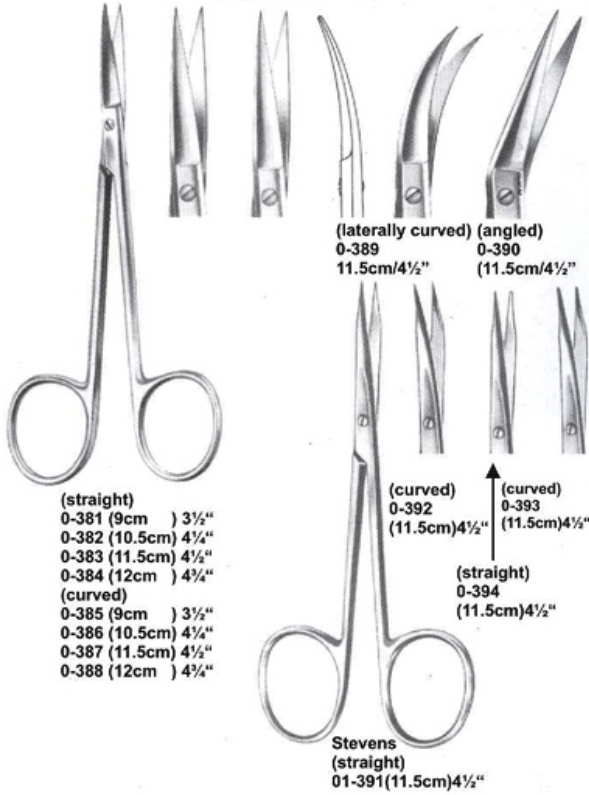

EYE SCISSORS

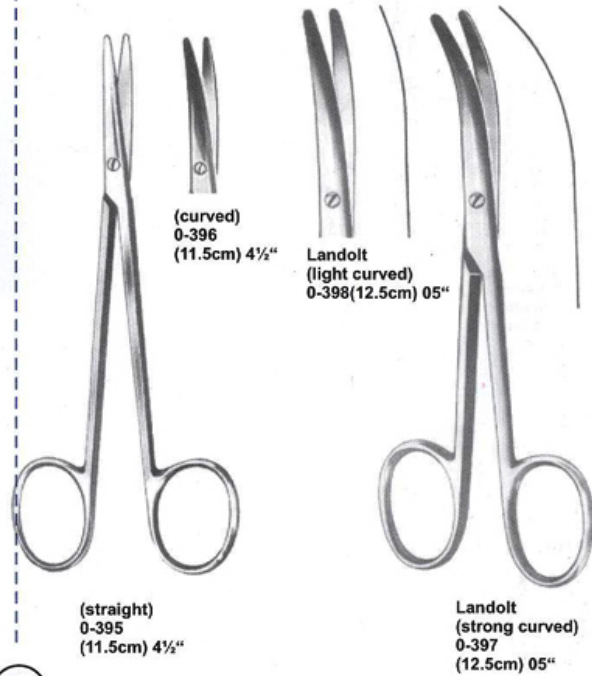

13

ENT SCISSORS



TONSIL SCISSORS

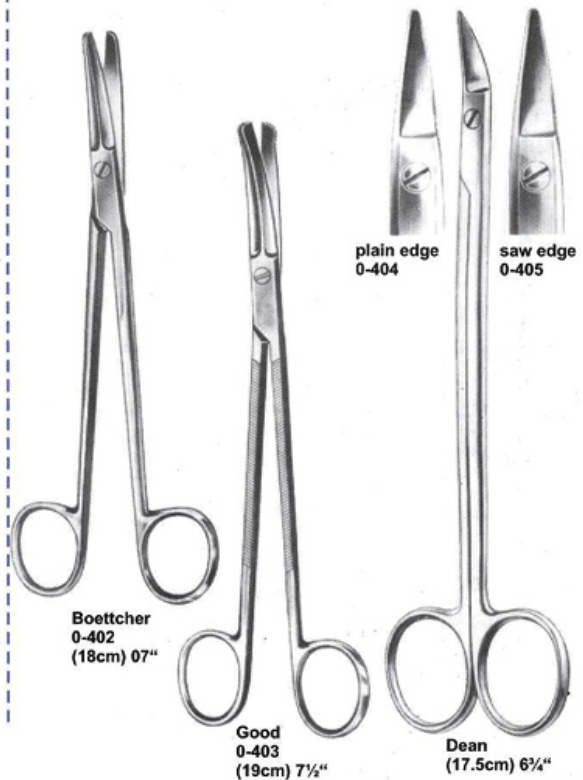

LIGATURE/DISSECTING SCISSORS

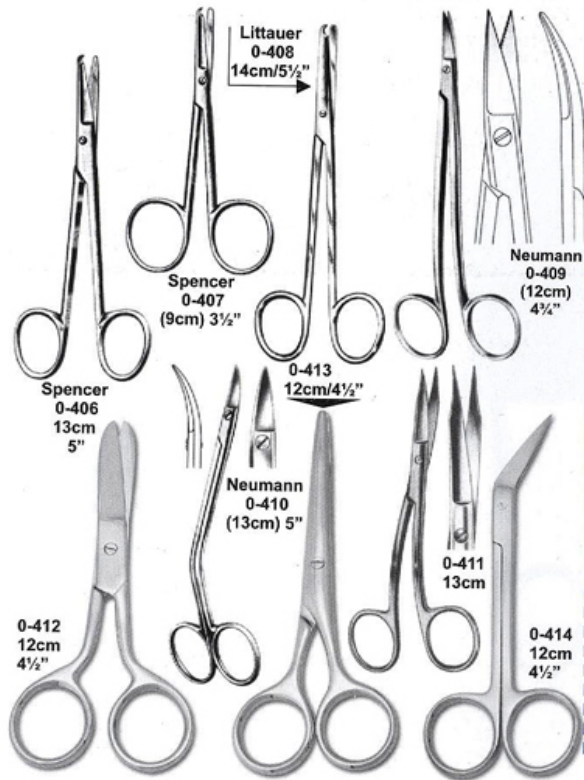

Umbilical Scissors



14

OPERATING SCISSORS

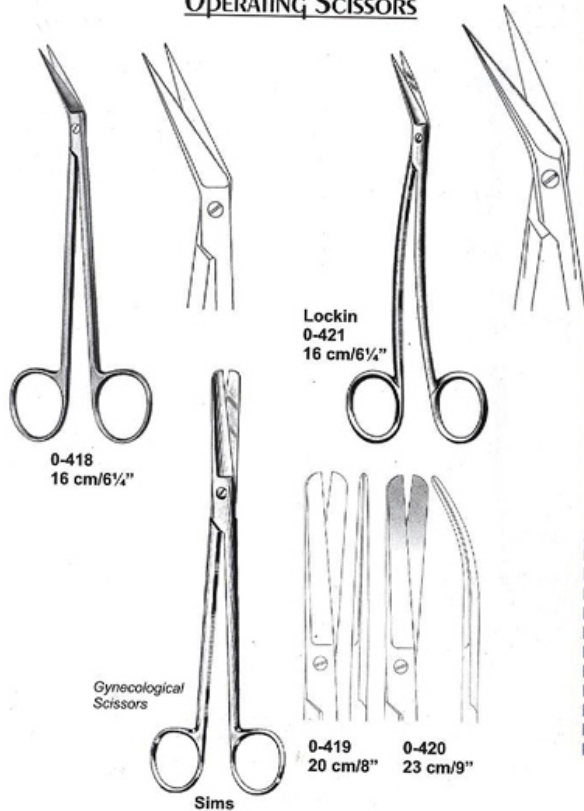

WIRE CUTTING, GUM SCISSORS

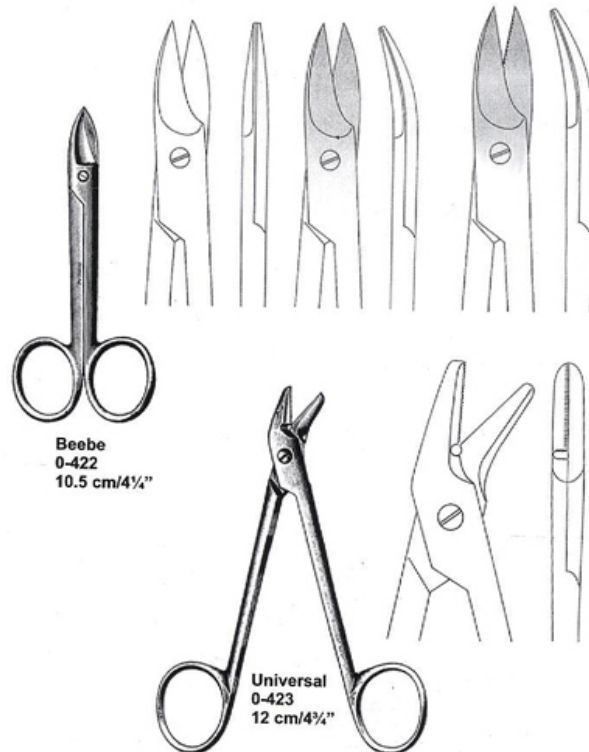

DRESSING FORCEPS

Standard

0-424	0-425	0-426	0-427	0-428
10.5cm/4 1/4"	11.5cm/4 1/2"	13cm/5"	14.5cm/5 1/4"	15cm/6"
0-429	0-430	0-431	0-432	0-433
16cm/6 1/4"	18cm/7"	20cm/8"	25cm/10"	30cm/12"

0-434	0-435	0-436	0-437	Slender
10.5cm/4 1/4"	11.5cm/4 1/2"	13cm/5"	14.5cm/5 1/4"	
0-438	0-439	0-440	0-441	0-442
16cm/6 1/4"	18cm/7"	20cm/8"	25cm/10"	30cm/12"

0-443	0-444	0-445	0-446	Slender
10.5cm/4 1/4"	11.5cm/4 1/2"	13cm/5"	14.5cm/5 1/4"	
0-447	0-448	0-449	0-450	0-451
16cm/6 1/4"	18cm/7"	20cm/8"	25cm/10"	30cm/12"

0-452	0-453	delicate
13cm/5"	14.5cm/5 1/4"	

0-454	0-455	delicate
13cm/5"	14.5cm/5 1/4"	

		with pin
0-456	0-457	delicate
13cm/5"	14.5cm/5 1/4"	

DRESSING FORCEPS

McIndoe



0-475
15cm/6"



Eng. pattern 0-476 0-477
13cm/5" 14.5cm/5 1/4"



Semken 0-478 0-479
12.5cm/5" 15.5cm/6"



Taylor 0-480
17.5cm/7"



Taylor 0-481
17.5cm/7"



Taylor 0-482
18.5cm/7 1/4"

DRESSING FORCEPS

Standard Mod.USA

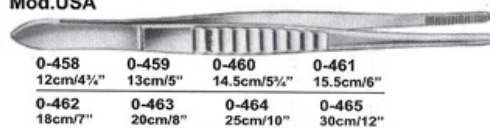

0-458 0-459 0-460 0-461
12cm/4 1/4" 13cm/5" 14.5cm/5 1/4" 15.5cm/6"

0-462 0-463 0-464 0-465
18cm/7" 20cm/8" 25cm/10" 30cm/12"



0-466 0-467 0-468 0-469
12cm/4 1/4" 13cm/5" 14.5cm/5 1/4" 15.5cm/6"

Slender Mod.USA

Adson



0-470 0-471
12cm/4 1/4" 15cm/6"

Micro Adson



0-472 0-473
12cm/4 1/4" 15cm/6"



Stille 0-474
15cm/6"

15

DRESSING FORCEPS

Gerald



0-483
17.5cm/7"



Gerald 0-484
17.5cm/7"



Cushing 0-485
18cm/7"



Cushing 0-486
18cm/7"



Potts-Smith 0-487 0-488 0-489
18cm/7" 21cm/8 1/4" 25cm/10"



Potts-Smith 0-490 0-491 0-492
18cm/7" 21cm/8 1/4" 25cm/10"

DRESSING FORCEPS

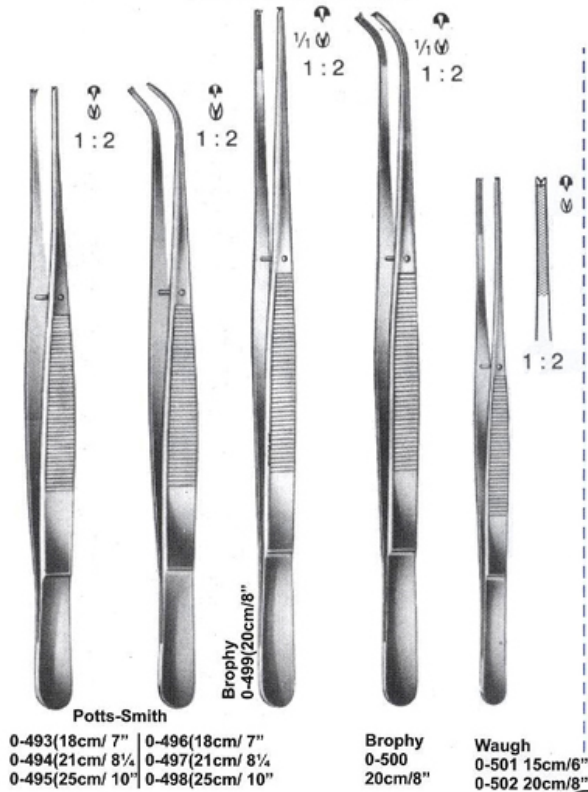

DRESSING FORCEPS



16

TISSUE FORCEPS

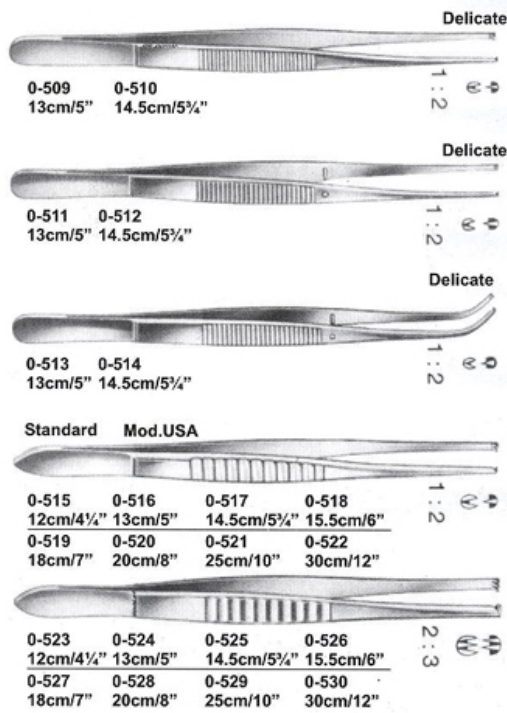

TISSUE FORCEPS

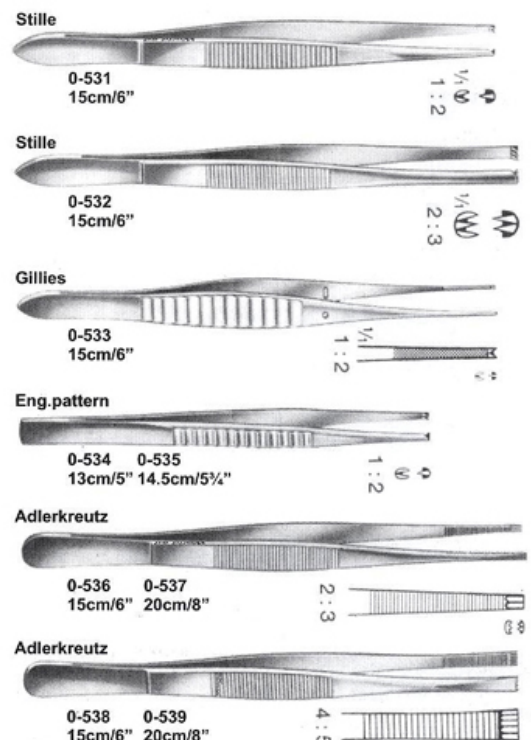

TISSUE FORCEPS

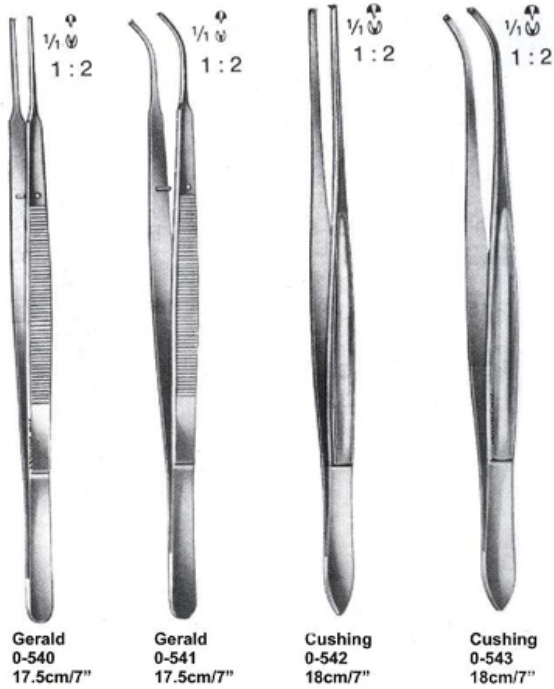

TISSUE FORCEPS

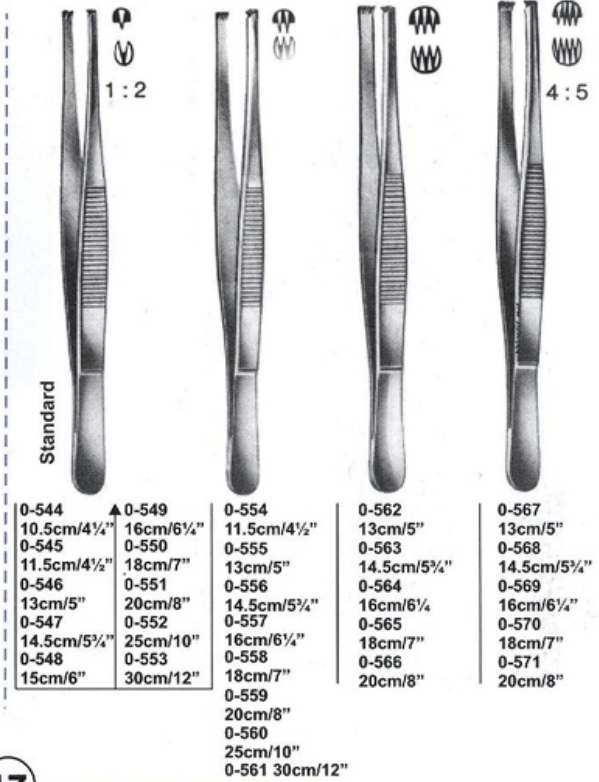

17

TISSUE FORCEPS

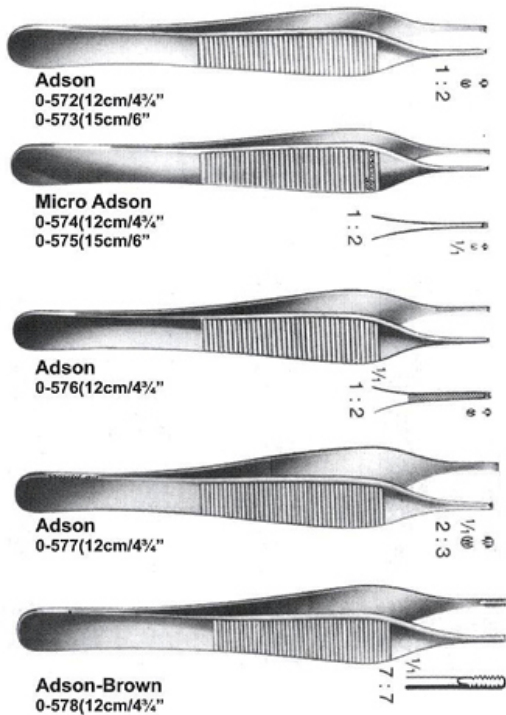

TISSUE FORCEPS

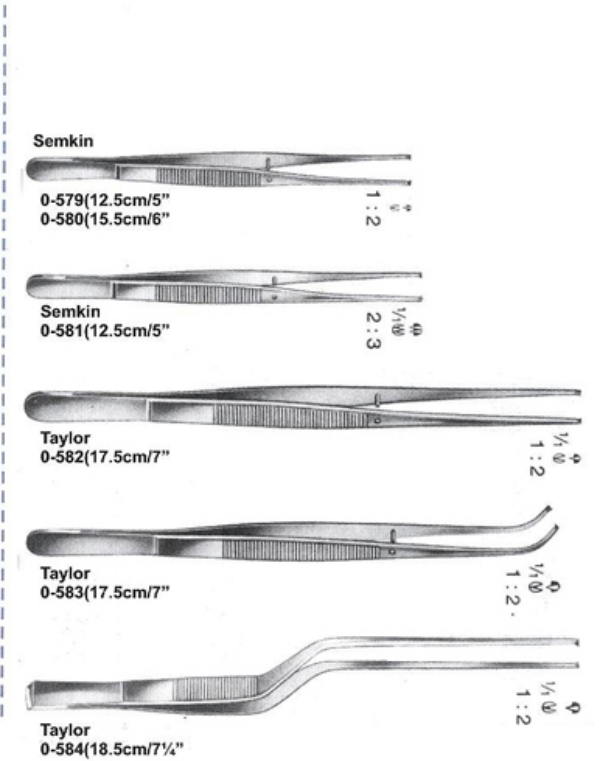

TISSUE FORCEPS

Bonney
0-585(18cm/7")
1:2



Bonney
0-586(18cm/7")
2:3

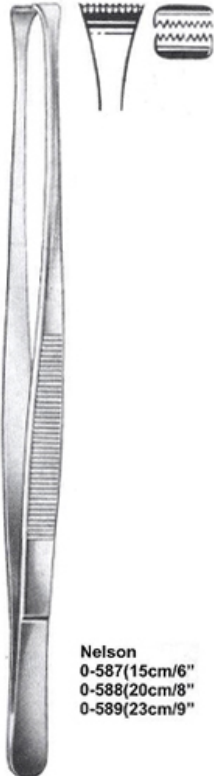

Nelson
0-587(15cm/6")
0-588(20cm/8")
0-589(23cm/9")

TISSUE FORCEPS



Lane
0-590(14.5cm/5 1/4")
0-591(20cm/8")

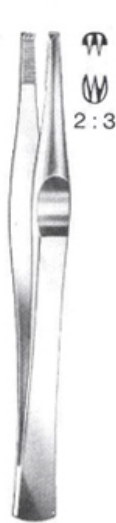

Lane
0-592(14.5cm/5 1/4")
0-593(20cm/8")



Brown
0-594(15cm/6")
0-595(20cm/8")



Treves
0-596(13cm/5")
0-597(15cm/6")

Cilia FORCEPS



Bergh
0-598(10.5cm)4 1/4"



Barraquer
0-599(10.5cm)4 1/4"



Gradle
0-600(10cm)4"



Henny
0-601(10cm)4"

Cilia FORCEPS



0-602
9cm)3 1/2"



0-603
9cm)3 1/2"



Douglas
0-604
9cm)3 1/2"



Douglas
0-605
9cm)3 1/2"



Beer
0-606(6.5cm)2 1/2"
0-607(8cm)3 1/4"
0-608(9cm)3 1/2"

SPLINTER FORCEPS



0-609(8cm)3¼"	0-615(8cm)3¼"	0-621(8cm)3¼"	0-627(8cm)3¼"
0-610(9cm)3½"	0-616(9cm)3½"	0-622(9cm)3½"	0-628(9cm)3½"
0-611(10.5cm)4¼"	0-617(10.5cm)4¼"	0-623(10.5cm)4¼"	0-629(10.5cm)4¼"
0-612(11.5cm)4½"	0-618(11.5cm)4½"	0-624(11.5cm)4½"	0-630(11.5cm)4½"
0-613(13cm)5"	0-619(13cm)5"	0-625(13cm)5"	0-631(13cm)5"
0-614(14.5cm)5½"	0-620(14.5cm)5½"	0-626(14.5cm)5½"	0-632(14.5cm)5½"

SPLINTER FORCEPS

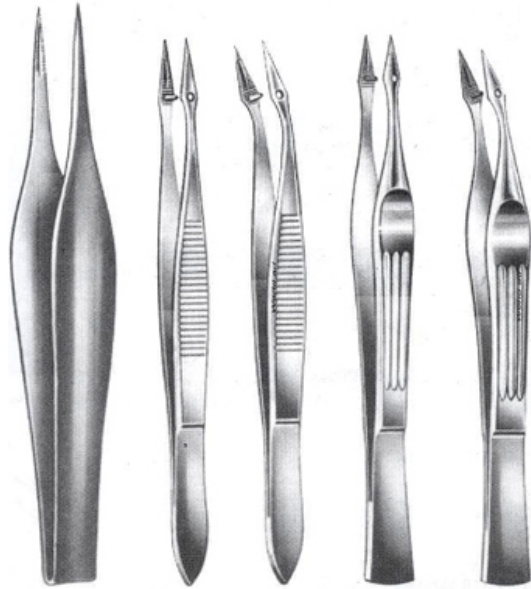

Feilchenfeld	Hunter	Water-Carmalt	Water-Carmalt
0-633(8cm)3¼"	0-636	0-638	0-639
0-634(9cm)3½"	(10.5cm)4¼"	(10.5cm)4¼"	(10.5cm)4¼"
0-635(11.5cm)4½"	Hunter		
	0-637		
	(10.5cm)4¼"		

19

TISSUE FORCEPS

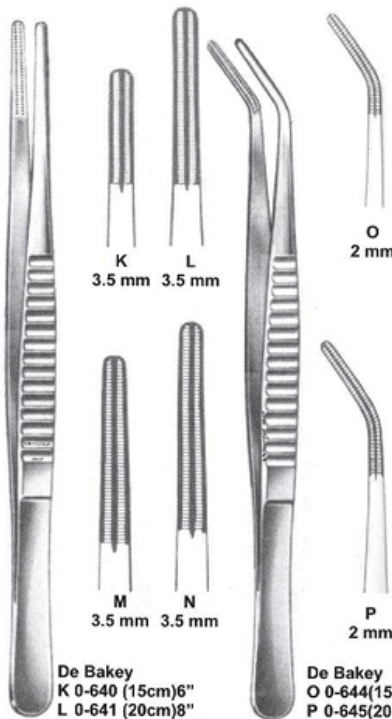

De Bakay	De Bakay
K 0-640 (15cm)6"	O 0-644(15cm)6"
L 0-641 (20cm)8"	P 0-645(20cm)8"
M 0-642 (24cm)9½"	
N 0-643 (30cm)12"	

TISSUE FORCEPS

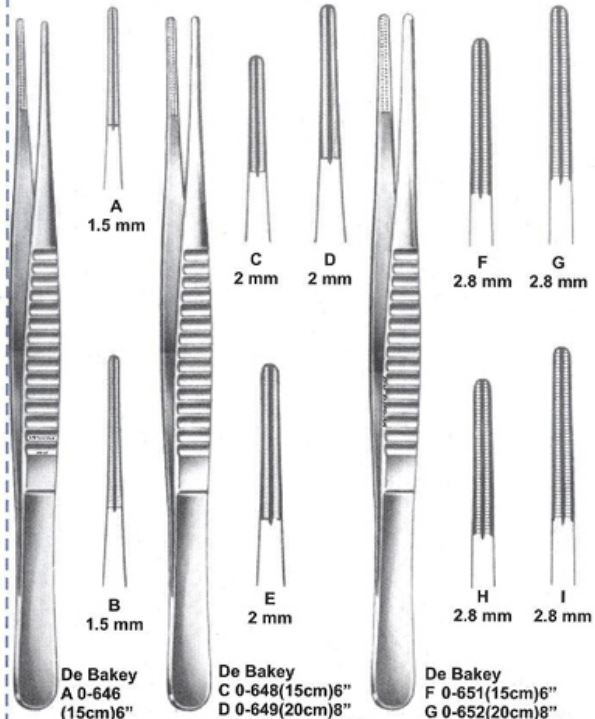

De Bakay	De Bakay	De Bakay
A 0-646	C 0-648(15cm)6"	F 0-651(15cm)6"
(15cm)6"	D 0-649(20cm)8"	G 0-652(20cm)8"
B 0-647	E 0-650(24cm)9½"	H 0-653(24cm)9½"
(20cm)8"		I 0-654(30cm)12"

Iris FORCEPS



Iris FORCEPS

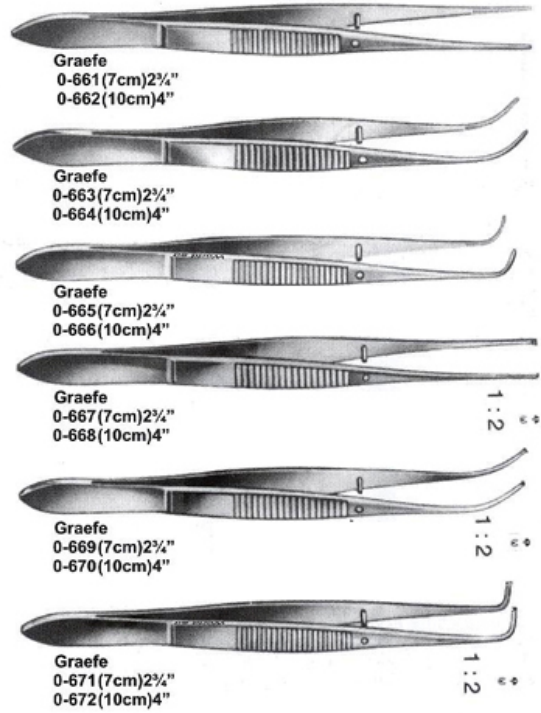

Iris FORCEPS

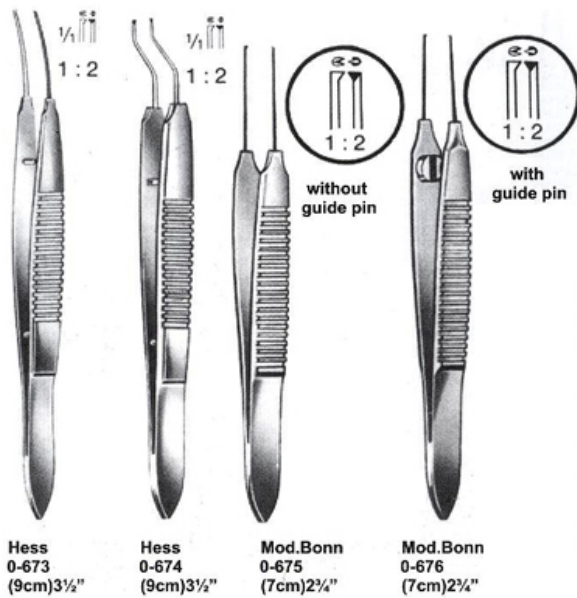

Iris FORCEPS

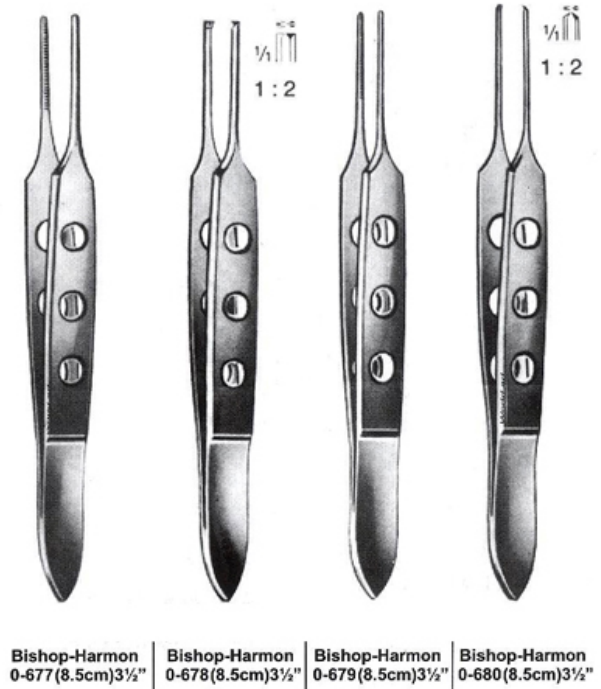

SUTURE FORCEPS

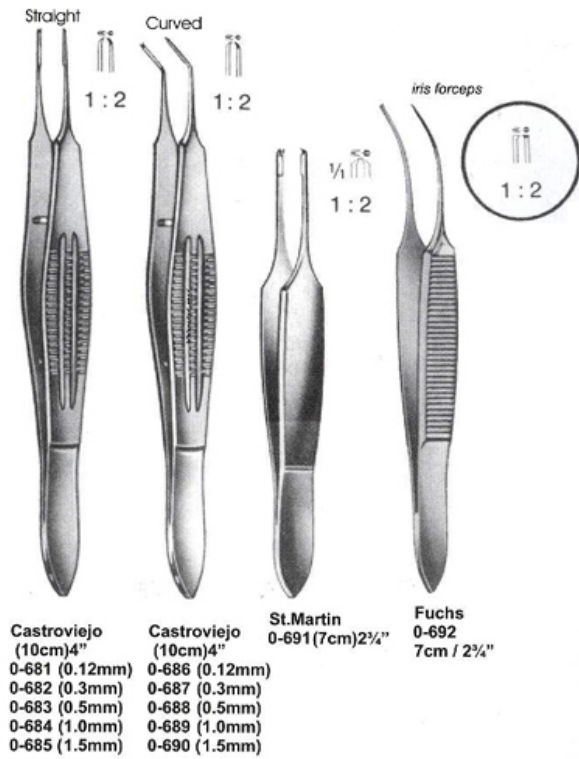

CAPSULAR FORCEPS

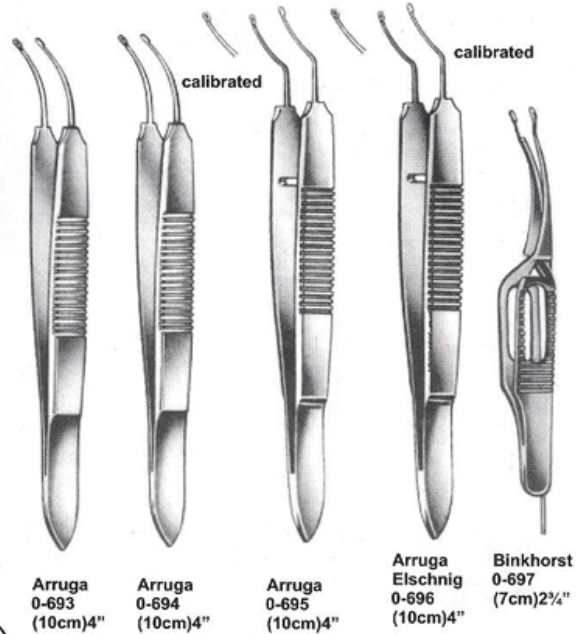

21

FIXATION & GRASPING FORCEPS

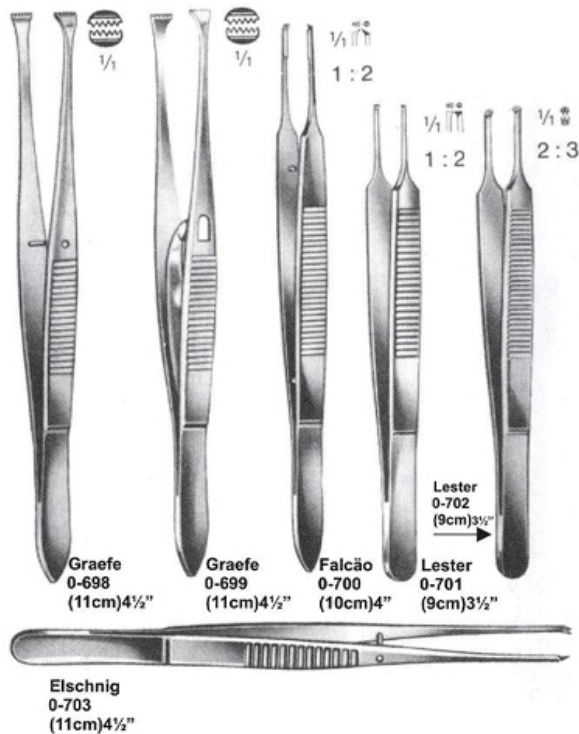

VARIOUS EYE FORCEPS

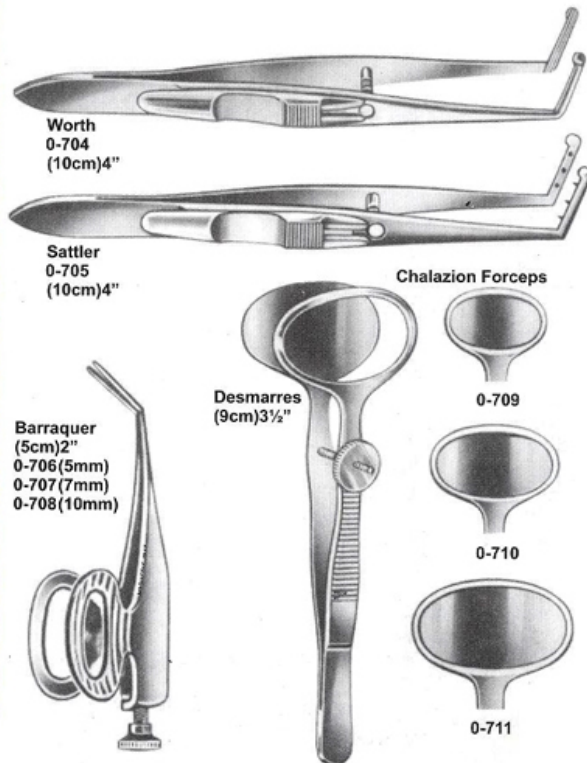

MICROSCOPIC & EYE SCISSORS

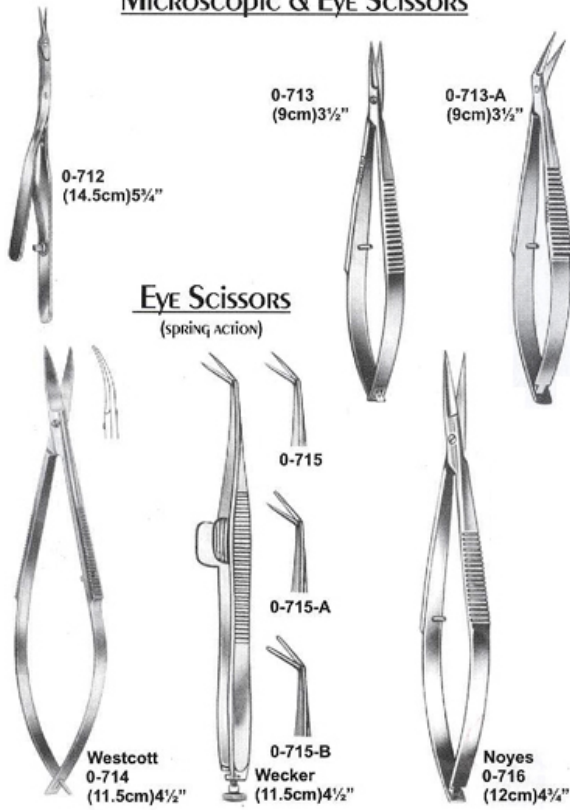

EYE SCISSORS (spring action)

EYE SCISSORS (spring action)

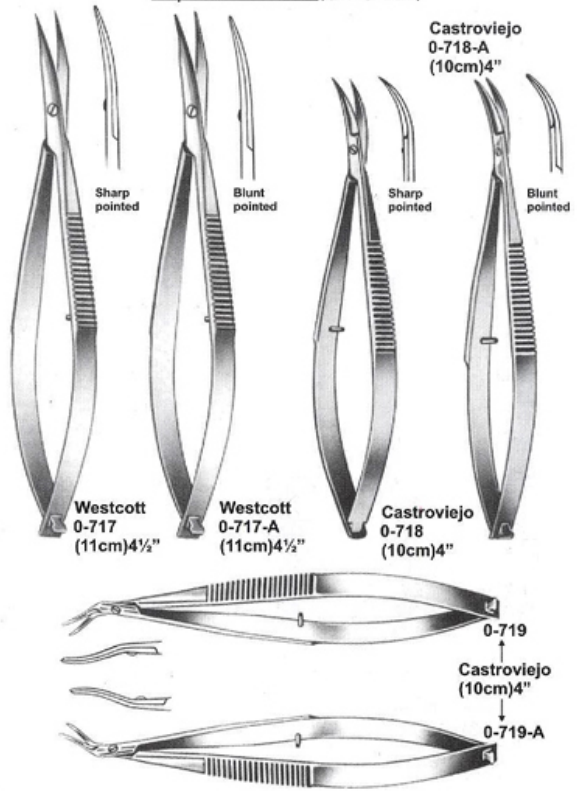

22

MICRO SCISSORS (spring action)

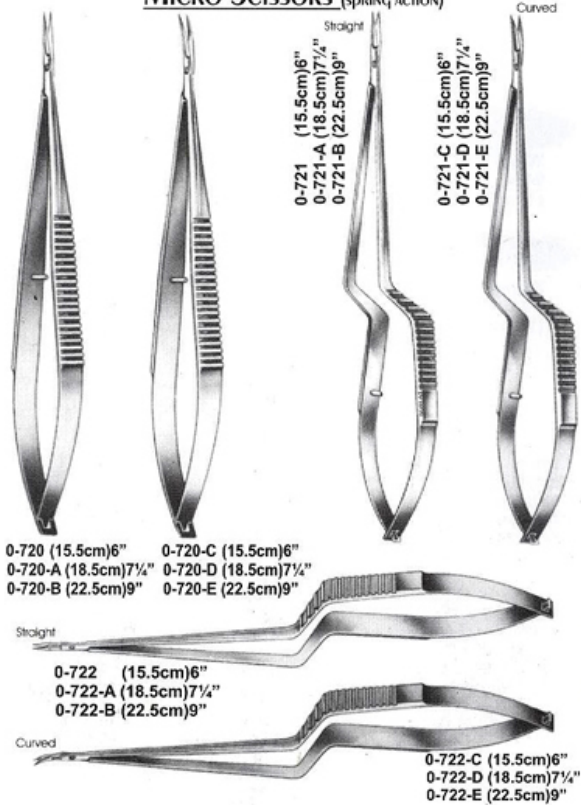

MICRO SCISSORS (spring action)

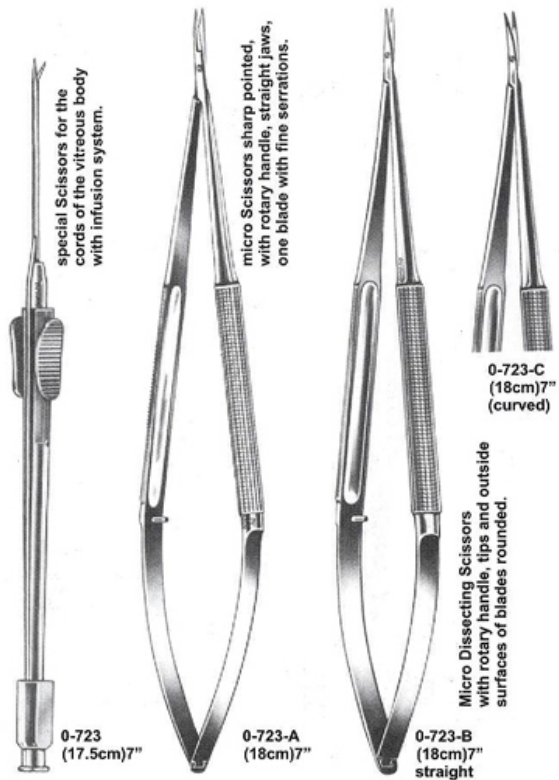

SUTURE INSTRUMENTS



Ochsner
0-723D
(14cm)5¼"



Lange
0-723E
(10cm)4"



Wachenfeldt
0-723F
(12cm)4½"

SUTURE INSTRUMENTS



Childe
0-723G
(18cm)7"



Michel
0-723H
(12cm)4¾"



Wachenfeldt
0-723J
(12.5cm)5"

SUTURE INSTRUMENTS



Hegenbarth
0-723K
(12.5cm)5"



Wachenfeldt
0-723L
(12.5cm)5"



Michel
0-723M
(12cm)4¾"



Mod-Michel
0-723N
(12cm)4¾"

SUTURE INSTRUMENTS

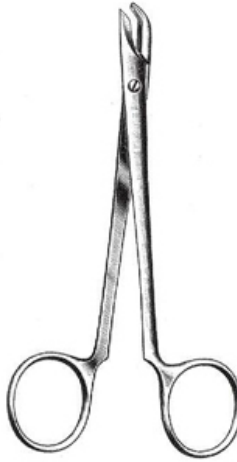

Collin
0-723P
(13cm)5"

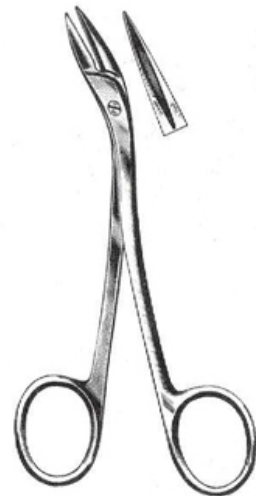

Richter-Heath
0-723R
(14cm)5½"

ARTERY FORCEPS

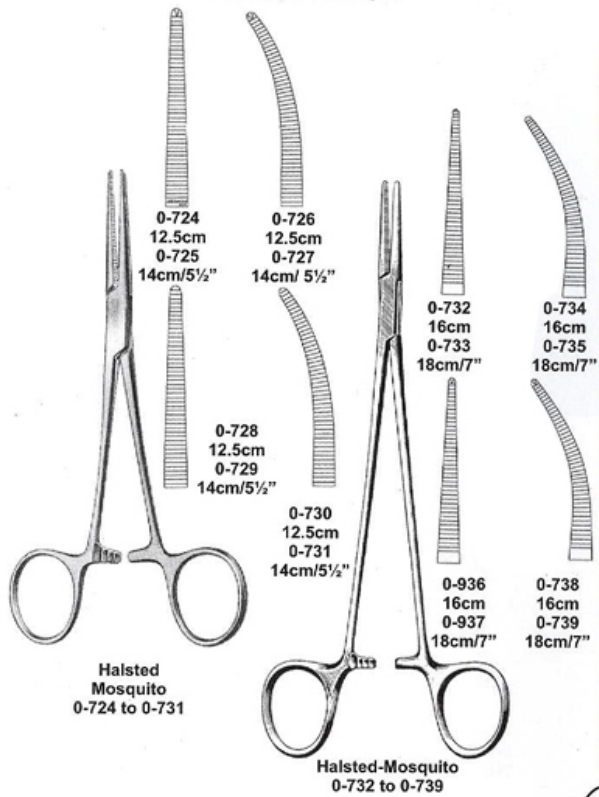

ARTERY FORCEPS

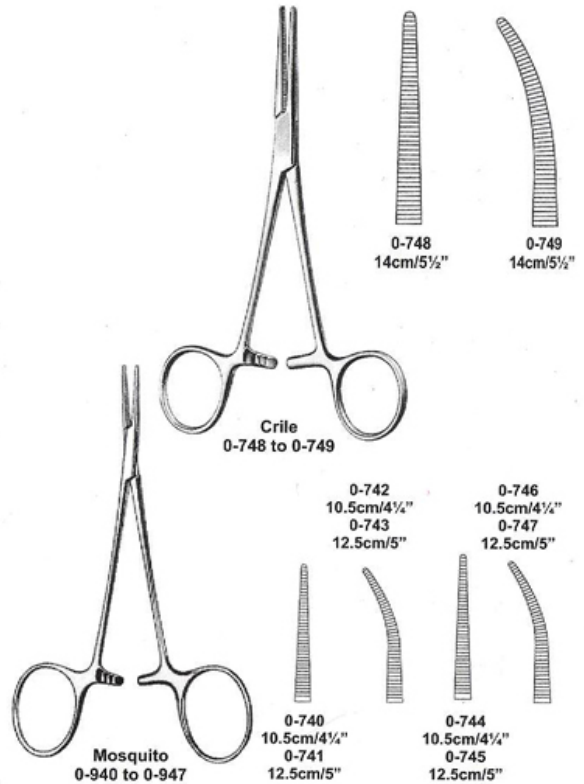

ARTERY FORCEPS

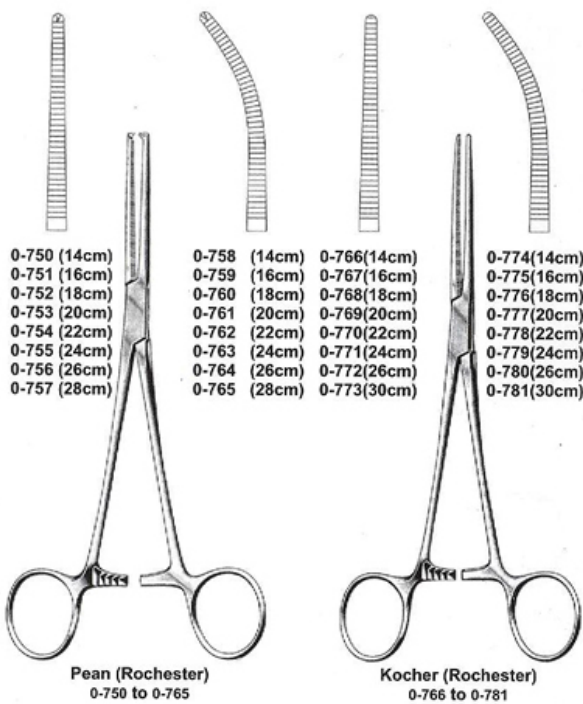

ARTERY FORCEPS

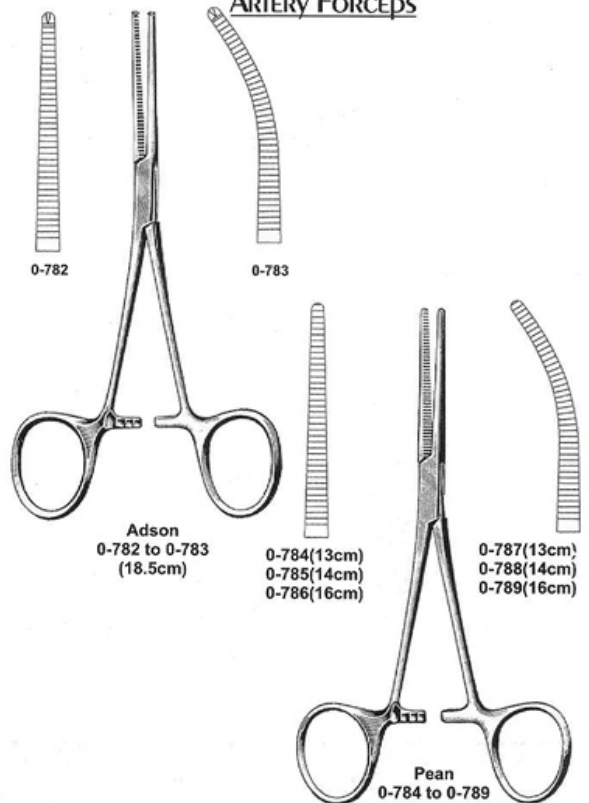

ARTERY FORCEPS

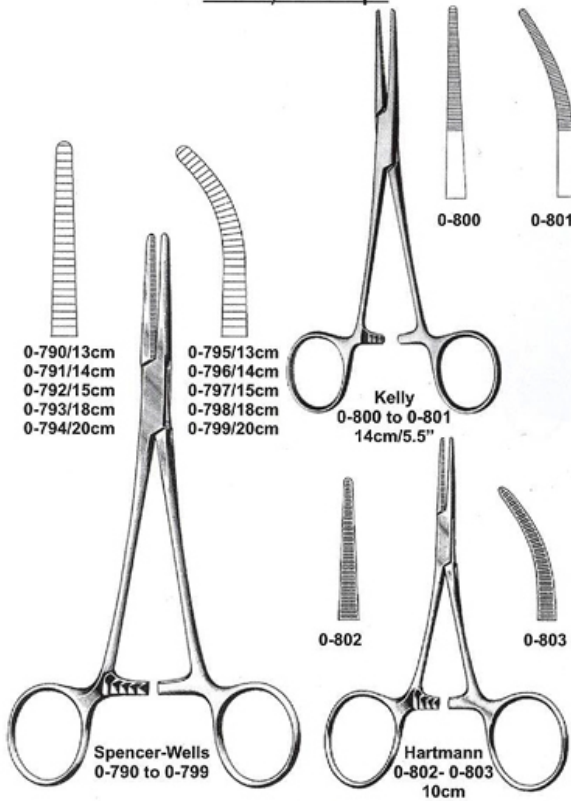

ARTERY FORCEPS

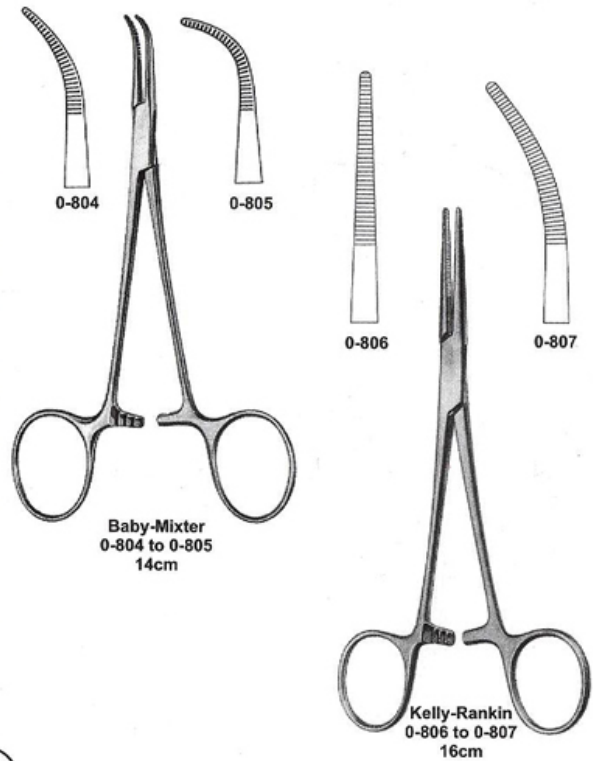

25

ARTERY & HYSTERECTOMY FORCEPS

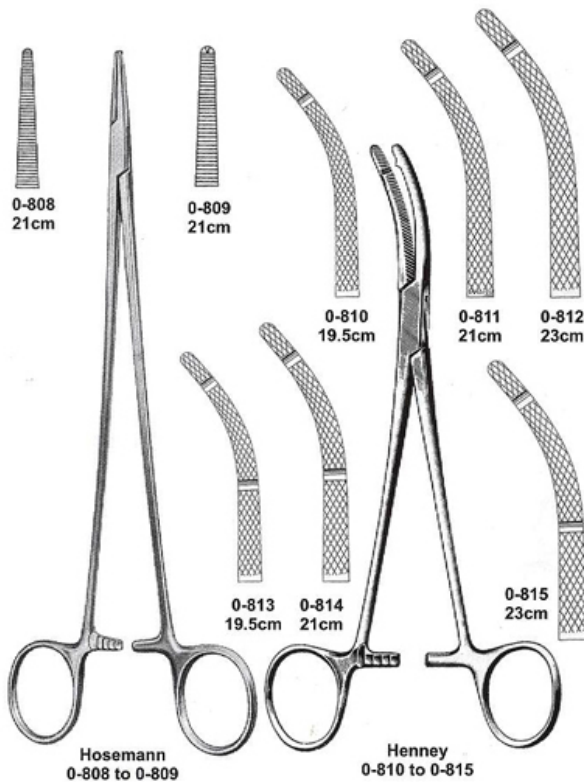

ARTERY & HYSTERECTOMY FORCEPS



NEEDLE HOLDERS

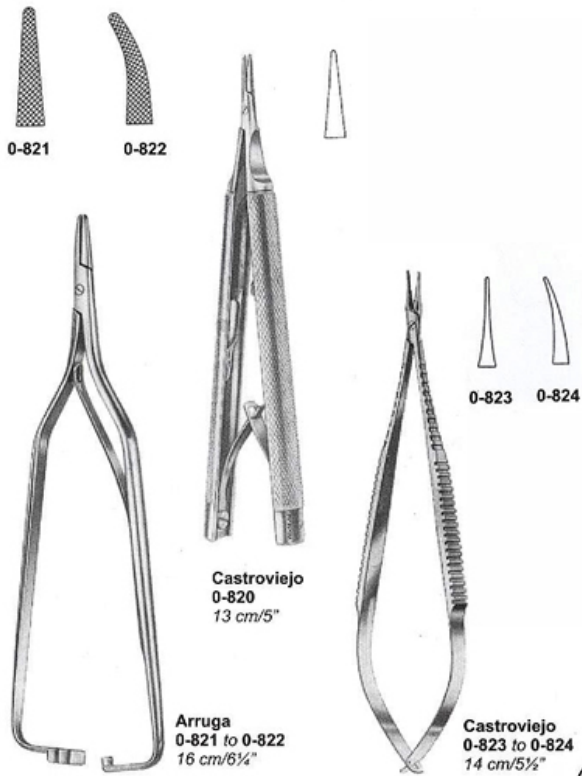

NEEDLE HOLDERS

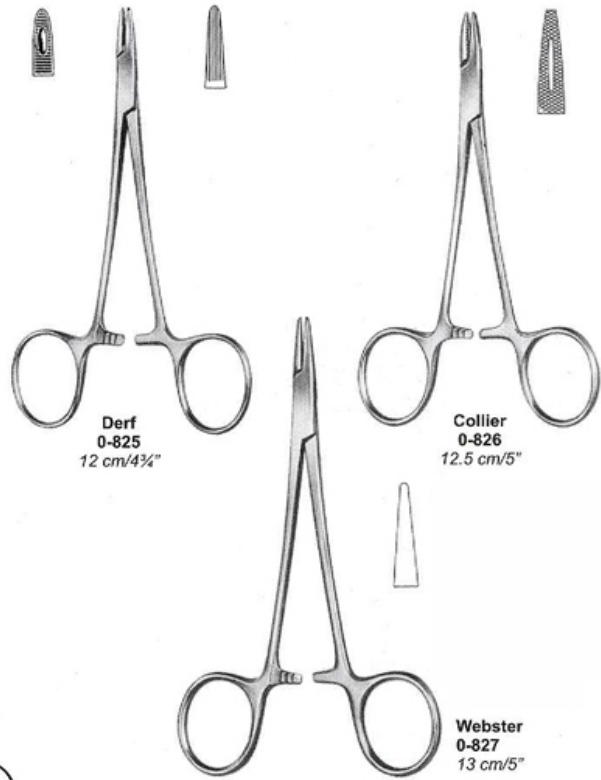

NEEDLE HOLDERS



NEEDLE HOLDERS

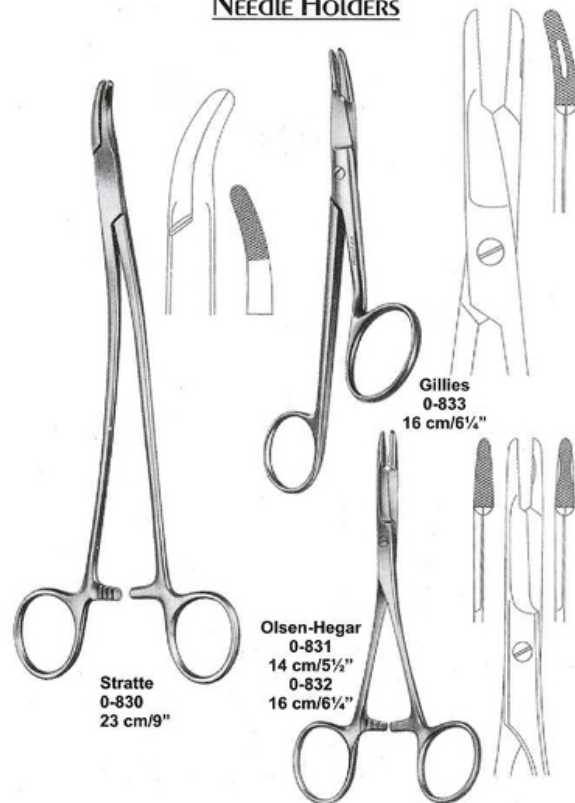

Sponge Holding Forceps



Foerster
0-903 to 0-909

- 0-903 (25cm)
- 0-904 (18cm)
- 0-905 (20cm)
- 0-906 (25cm)
- 0-907 (25cm)
- 0-908 (18cm)
- 0-909 (20cm)
- 0-910 (25cm)

Sponge & Dressing Forceps

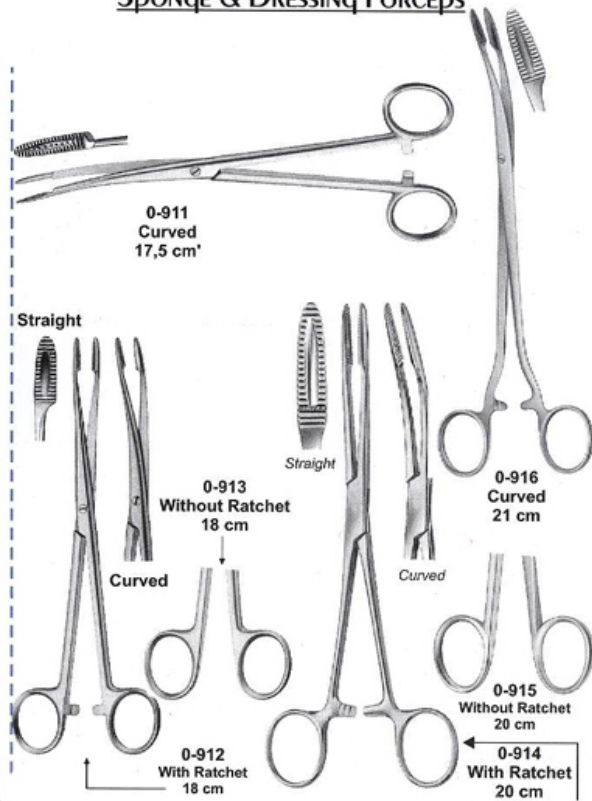

Straight

Straight

- 0-911 Curved 17,5 cm'
- 0-912 With Ratchet 18 cm
- 0-913 Without Ratchet 18 cm
- 0-914 With Ratchet 20 cm
- 0-915 Without Ratchet 20 cm
- 0-916 Curved 21 cm

30

Tissu & Organ Holding Forceps

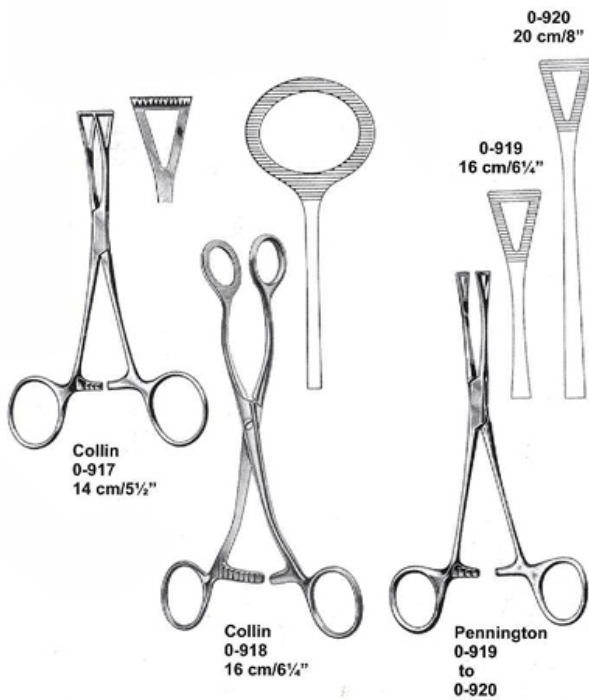

Collin
0-917
14 cm/5½"

Collin
0-918
16 cm/6¼"

0-919
16 cm/6¼"

Pennington
0-919
to
0-920

0-920
20 cm/8"

Tongue Holding Forceps

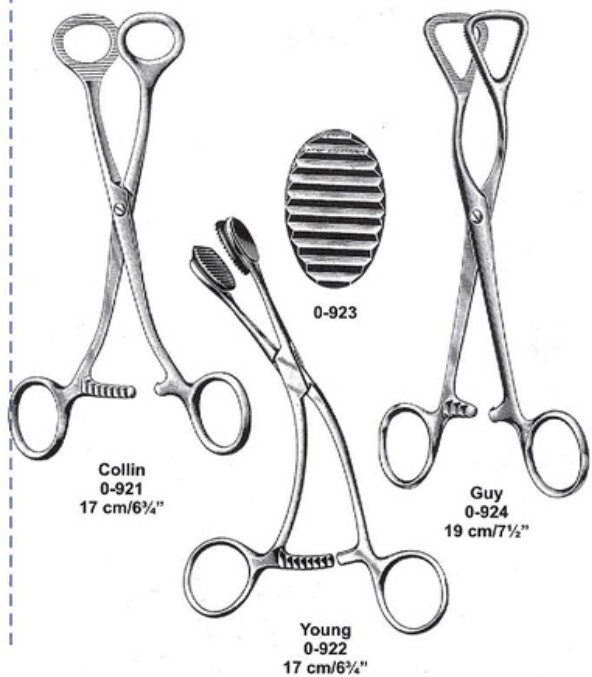

Collin
0-921
17 cm/6¼"

Young
0-922
17 cm/6¼"

0-923

Guy
0-924
19 cm/7½"

TONGUE DEPRESSORS,

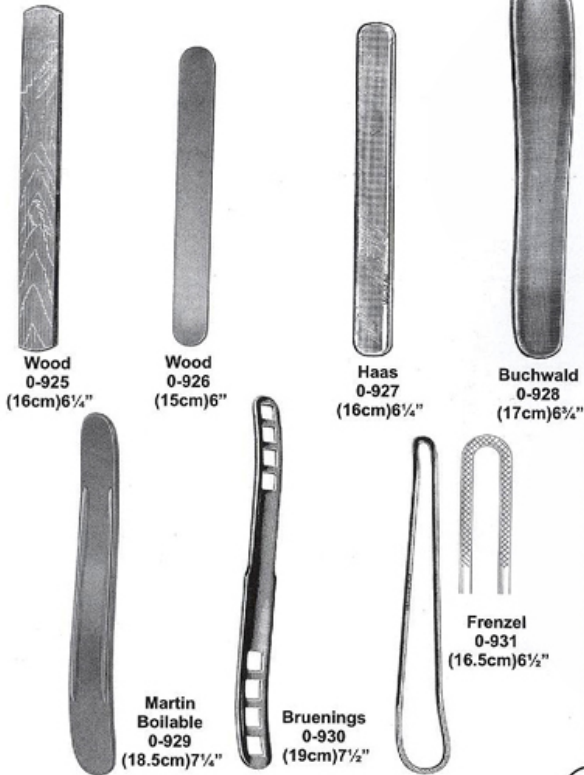

MOUTH GAGS

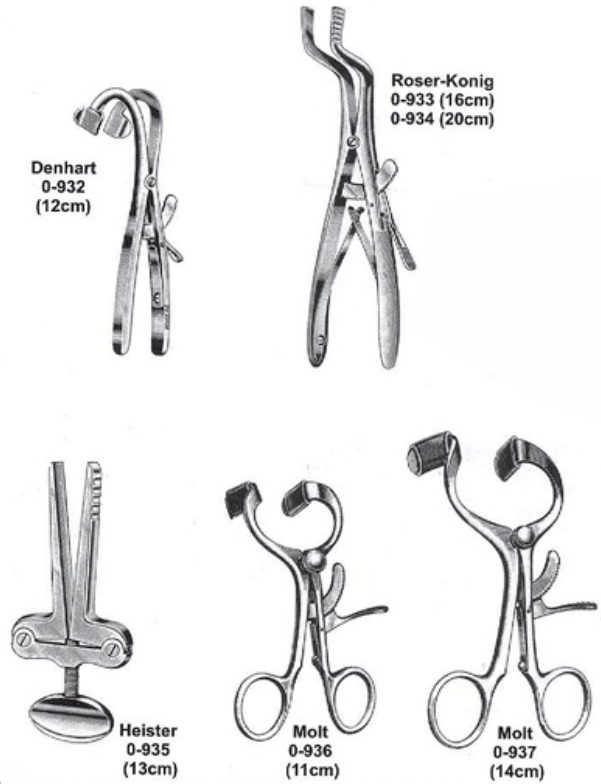

CHEEK & Lip RETRACTORS

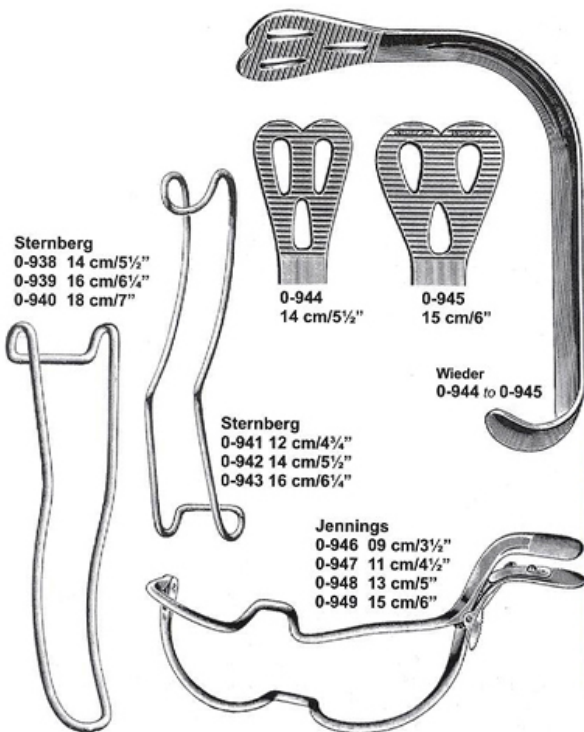

TONGUE DEPRESSORS,



VAGINAL SPECULA



VAGINAL SPECULA



36

VAGINAL SPECULA

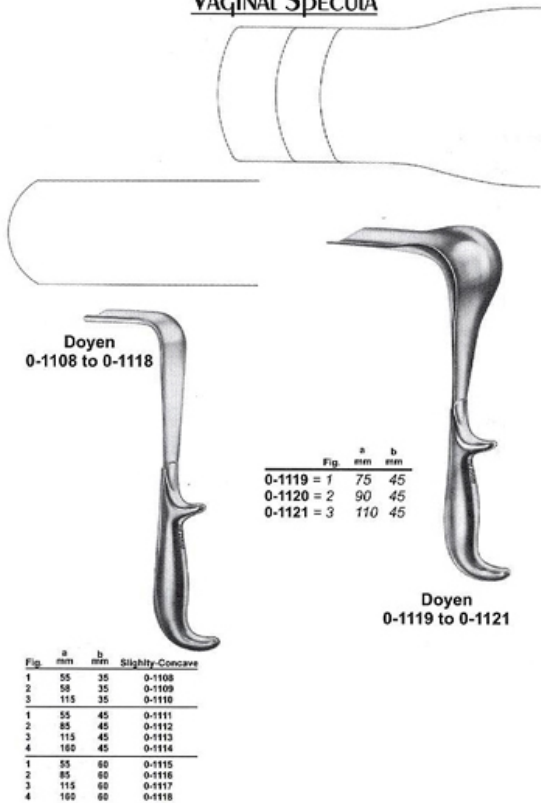

VAGINAL SPECULA & RETRACTORS

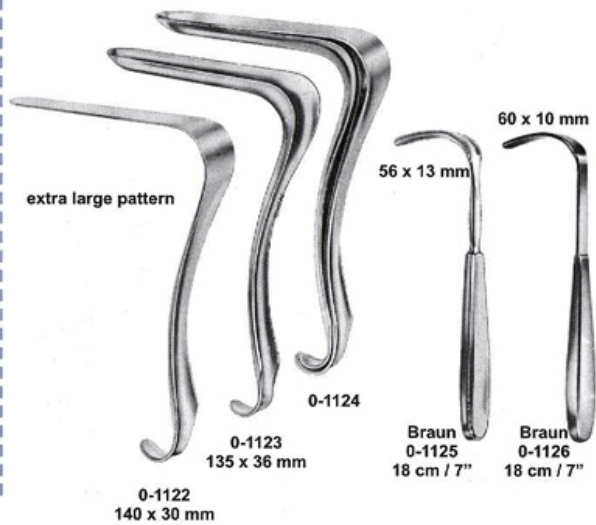

VAGINAL SPECULA & RETRACTORS

Sims
0-1127
65 x 25 mm
70 x 30 mm
0-1128
70 x 30 mm
70 x 35 mm
0-1129
85 x 35 mm
90 x 40 mm

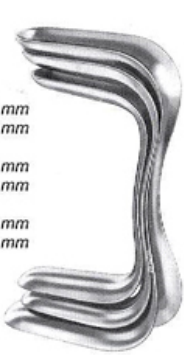

Jackson
0-1130
75 x 35 mm
0-1131
90 x 35 mm
0-1132
100 x 35 mm
0-1133
75 x 40 mm
0-1134
90 x 40 mm
0-1135
100 x 40 mm



VAGINAL SPECULA & RETRACTORS

Kristeller Specula
0-1144 Fig. 1
70 x 27 mm
0-1145 Fig. 2
80 x 30 mm
0-1146 Fig. 3
90 x 36 mm

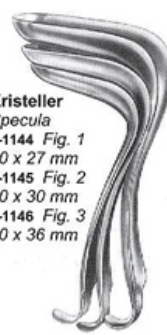

Kristeller Retractors
0-1147 Fig. 1
75 x 23 mm
0-1148 Fig. 2
85 x 26 mm
0-1149 Fig. 3
100 x 32 mm

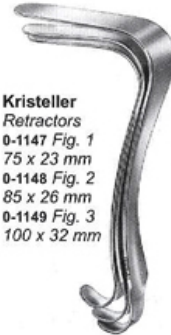

Kristeller
Set of 1 Speculum & 1 Retractor each
0-1150 Fig. 1
0-1151 Fig. 2
0-1152 Fig. 3



With Conically Shaped blades, Virgin Sizes



Kallmorgen Vaginal Specula
0-1136
70 x 40 mm
0-1137
90 x 40 mm

Vaginal Retractors
0-1138
70 x 33 mm
0-1139
90 x 33 mm

Mathieu Vaginal Specula
0-1140
95 x 16 mm
0-1141
95 x 16 mm
95 x 30 mm

Vaginal Retractors
0-1142
100 x 11 mm
100 x 20 mm
0-1143
100 x 14 mm
100 x 26 mm



Kristeller Specula
0-1153
105 x 18 mm
0-1154
105 x 21 mm

Kristeller Retractors
0-1155
110 x 14 mm
0-1156
110 x 17 mm

Kristeller
Set of 1 Speculum & 1 Retractor each
0-1157
0-1158

37

VAGINAL SPECULA

Specula flat hollow

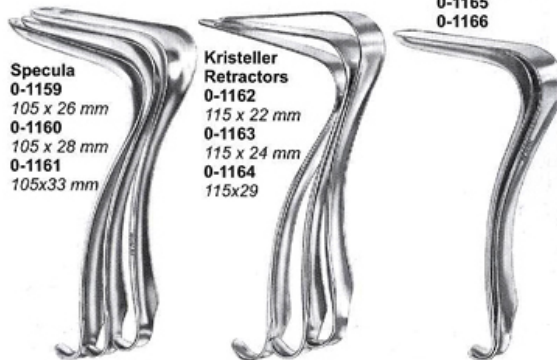

Specula
0-1159
105 x 26 mm
0-1160
105 x 28 mm
0-1161
105 x 33 mm

Kristeller Retractors
0-1162
115 x 22 mm
0-1163
115 x 24 mm
0-1164
115 x 29 mm

Kristeller
Set of 1 Speculum & 1 Retractor each
0-1165
0-1166

VAGINAL SPECULA

Specula Deep Hollow



Kristeller Specula
0-1167
110 x 27 mm
0-1168
110 x 30 mm
0-1169
110 x 36 mm



Kristeller Retractors
0-1170
115 x 23 mm
0-1171
115 x 26 mm
0-1172
115 x 32 mm



Kristeller
Set of 1 Speculum & 1 Retractor each
0-1173
0-1174
0-1175



RETRACTORS

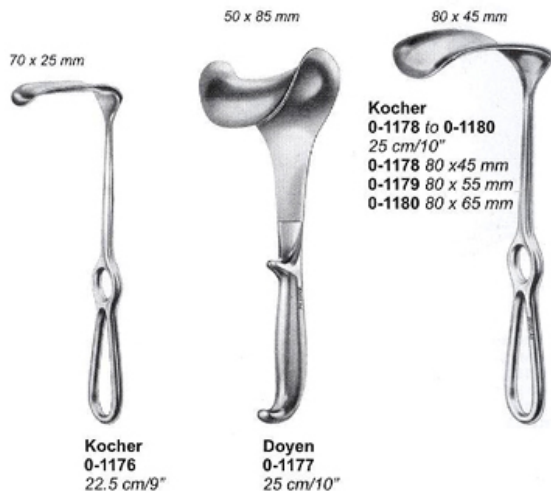

Kocher
0-1176
22.5 cm/9"

Doyen
0-1177
25 cm/10"

Kocher
0-1178 to 0-1180
25 cm/10"
0-1178 80 x 45 mm
0-1179 80 x 55 mm
0-1180 80 x 65 mm

PROSTATIC RETRACTORS



Young
0-1181
21 cm /8 1/4"

Young
0-1182
22 cm /8 3/4"

Young
0-1183
21 cm /8 1/4"

Young
0-1184
22 cm /8 3/4"

38

VAGINAL SPECULUM, RETRACTORS

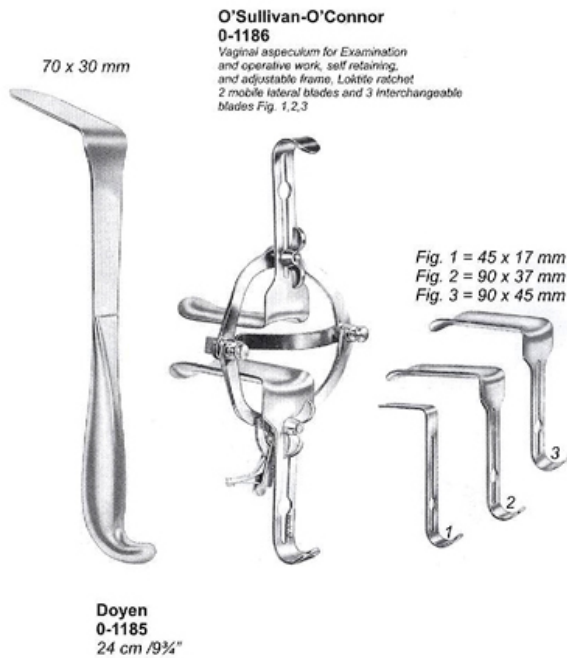

O'Sullivan-O'Connor
0-1186
Vaginal speculum for Examination and operative work, self retaining, and adjustable frame. Locking ratchet 2 mobile lateral blades and 3 interchangeable blades Fig. 1, 2, 3

Fig. 1 = 45 x 17 mm
Fig. 2 = 90 x 37 mm
Fig. 3 = 90 x 45 mm

Doyen
0-1185
24 cm /9 3/4"

VAGINAL SPECULUM, RETRACTORS



- 0-1187 = 100 x 20 mm
- 0-1188 = 100 x 25 mm
- 0-1189 = 100 x 30 mm
- 0-1190 = 100 x 35 mm
- 0-1191 = 100 x 40 mm

- 0-1192 = 130 x 20 mm
- 0-1193 = 130 x 25 mm
- 0-1194 = 130 x 30 mm
- 0-1195 = 130 x 35 mm
- 0-1196 = 130 x 40 mm

- 0-1197 = 155 x 40 mm

- 0-1198 = 105 x 28 mm
- 0-1199 = 105 x 38 mm

Breisky
0-1187 - 0-1197

Landau
0-1198 - 0-1199

Dunkel
0-1200

**ANAL RETRACTORS, RECTAL SPECULA
SPHINCTEROSCOPES, ANOSCOPE, PROCTOSCOPES**



Newman
0-1201 16 mm Ø x 63 mm
0-1202 19 mm Ø x 63 mm
0-1203 23 mm Ø x 63 mm



Kelly
0-1204 21 mm Ø x 50 mm
0-1205 27 mm Ø x 50 mm



Kelly
0-1206 22 mm Ø x 50 mm
0-1207 22 mm Ø x 100 mm
0-1208 22 mm Ø x 140 mm

**RECTAL SPECULA, ANAL
RETRACTORS, ANOSCOPE**

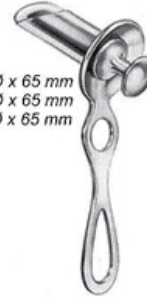

Hirschmann
0-1209 16 mm Ø x 65 mm
0-1210 19 mm Ø x 65 mm
0-1211 22 mm Ø x 65 mm



Ives-Fansler
0-1212
22 mm Ø



Ives-Fansler
0-1213
22 mm Ø

39

RETRACTORS

RETRACTORS



Richardson
0-1214 to 0-1216
24 cm

Richardson
0-1217
24 cm

Kelly
0-1218
26 cm

Richardson-Eastmann
0-1219 Fig. 1 26 cm
0-1220 Fig. 2 28 cm

Deaver

0-1224-A 23 cm
0-1224-B 21.5 cm
0-1224-C 18 cm



Deaver
0-1221
30 cm

Deaver
0-1222
30 cm

Deaver
0-1223
30 cm

Deaver
0-1224-
30 cm

Deaver
0-1225
36 cm

RETRACTORS

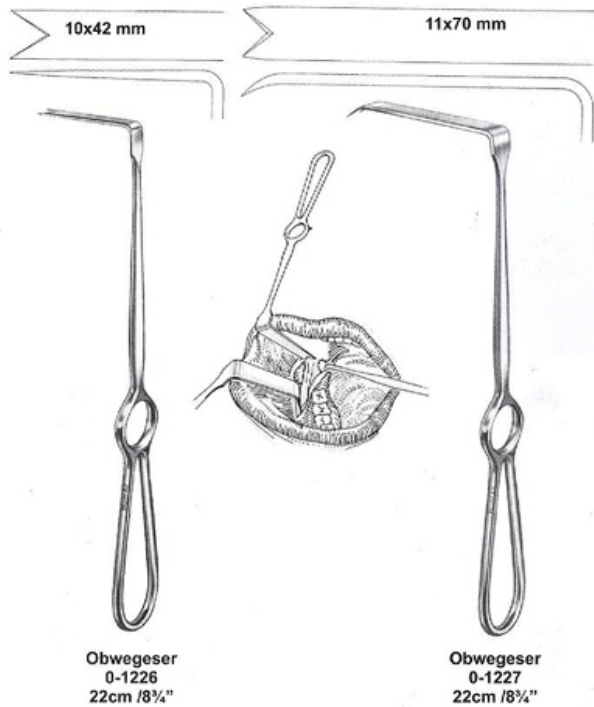

RETRACTORS

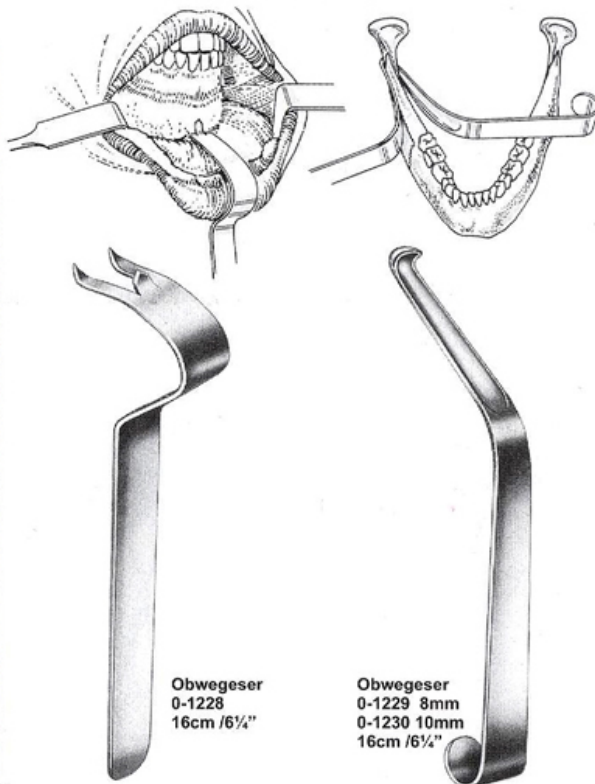

RHINOPLASTIC INSTRUMENTS

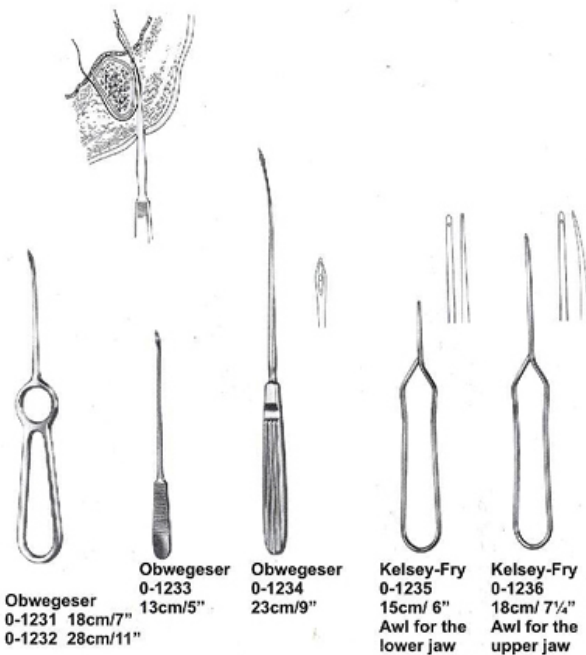

RHINOPLASTIC INSTRUMENTS



RECTAL SPECULA, ANAL RETRACTORS



RECTAL SPECULA



RECTAL SPECULA

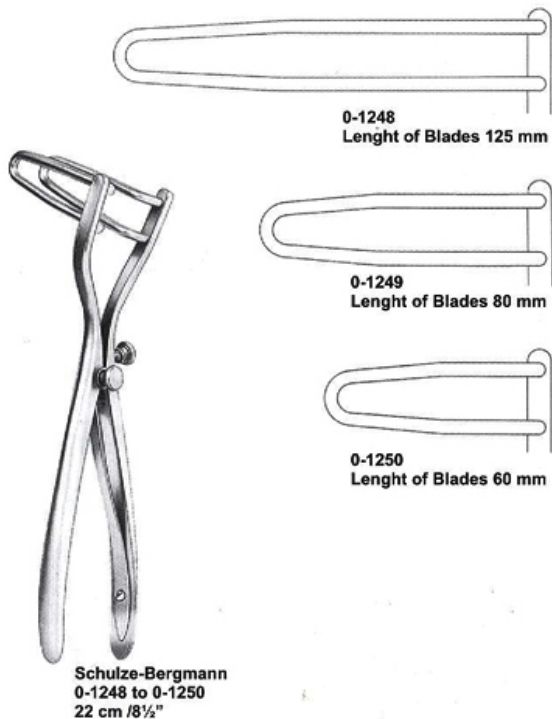

RECTAL SPECULA, ANAL RETRACTORS

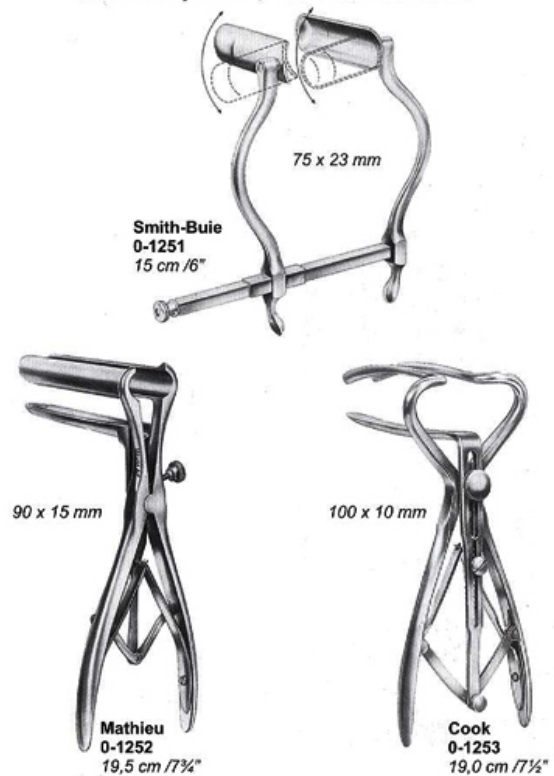

Abdominal Retractors

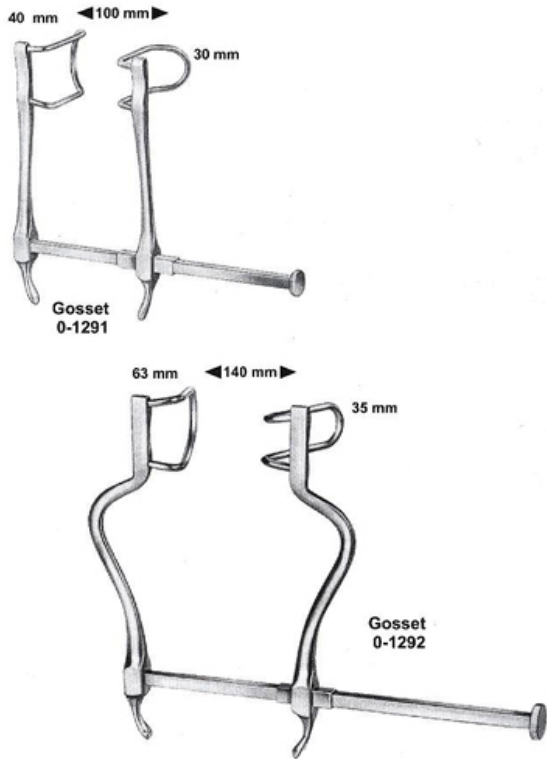

Abdominal Retractors

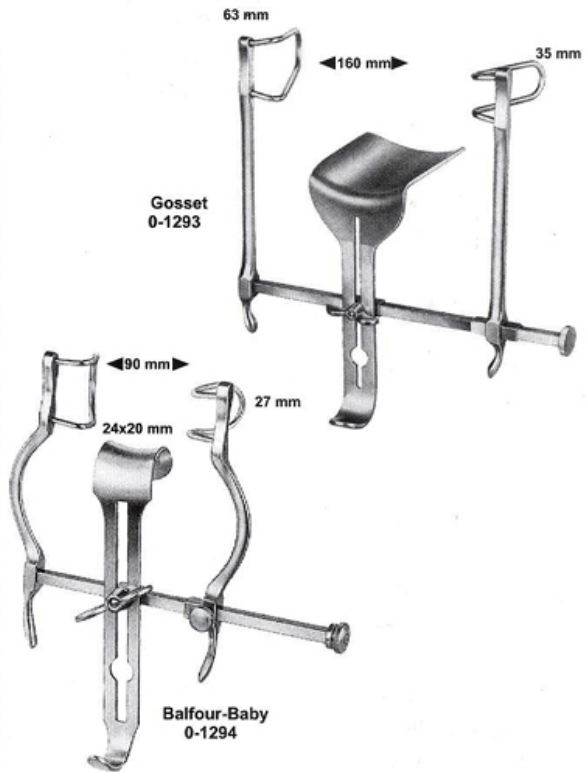

Abdominal Retractors

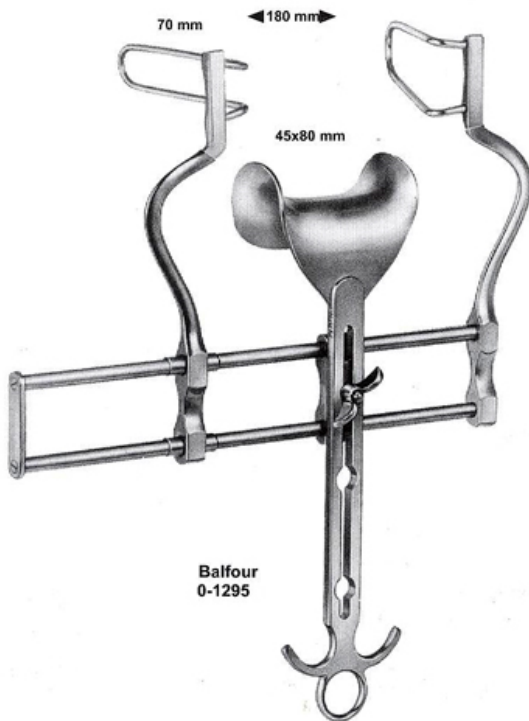

Abdominal Retractors

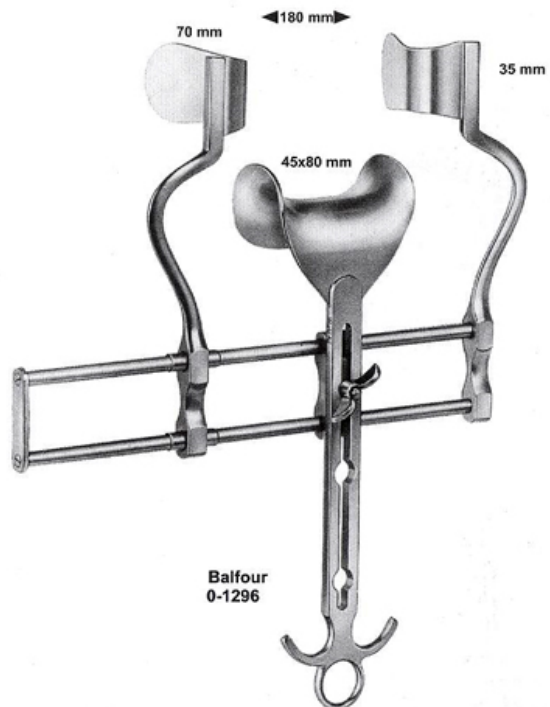

RETRACTORS



0-1297
45x45 mm



Middeldorp
25.5cm / 10"



0-1298
45x50 mm



0-1299
55x70 mm

RETRACTORS

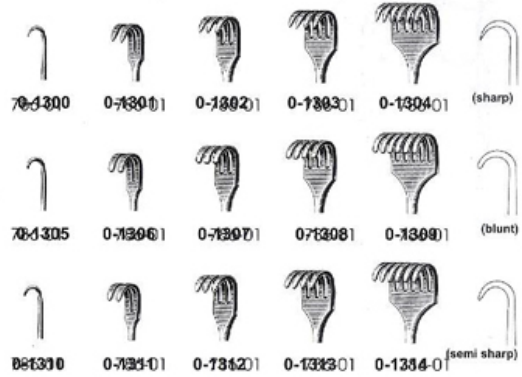

Volkman
0-1300 to 0-1318
21.5cm/8½"



Volkman
0-1315
21.5cm/8½"



Volkman
0-1316
21.5cm/8½"



Volkman
0-1317(sharp)
20cm/8"
0-1318(blunt)
20cm/8"

RETRACTORS



0-1319 45x40 mm
0-1320 45x50 mm
0-1321 45x60 mm
0-1322 45x75 mm

Fritsch
24 cm/9½"

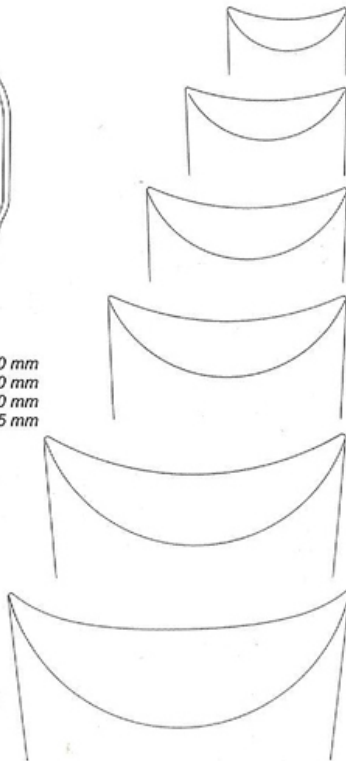

RETRACTORS



0-1324
36x60 mm

33x20 mm

0-1327
40x30mm
blunt

0-1323
36x30 mm

0-1326
40x30 mm
sharp

Ollier
22.5cm / 9"

Wassmund
0-1325
20cm / 8"

Wassmund
23.5cm / 9¼"

RETRACTORS



**Gelpi-Loktite
0-1328**
13 cm/5"



**Gelpi-Seiletz
0-1329**
15 cm/6"

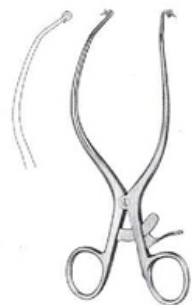

**Gelpi-Loktite
0-1330**
18 cm/7"

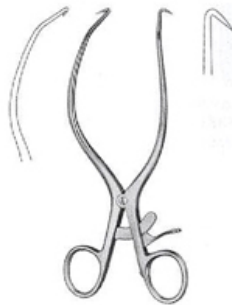

**Gelpi-Loktite
0-1331**
18 cm/7"

RETRACTORS



**Israel
0-1332 to 0-1335**
25 cm/10"



0-1332
40 x 40 mm



0-1333
40 x 50 mm



0-1334
50 x 60 mm

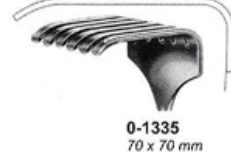

0-1335
70 x 70 mm



**Langenbeck
0-1336
to
0-1340**
21 cm/8 1/4"



0-1336
30 x 11 mm



0-1337
30 x 14 mm



0-1338
30 x 16 mm

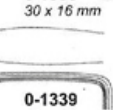

0-1339
40 x 11 mm

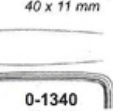

0-1340
50 x 11 mm

RETRACTORS

**Weitlaner-Wullstein
0-1341 sharp
0-1342 blunt**
13 cm/5"

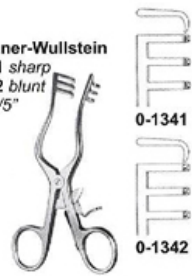

0-1341

0-1342

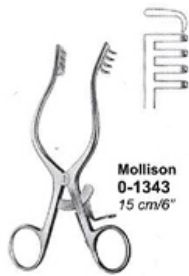

**Mollison
0-1343**
15 cm/6"



**Adson
0-1344 to 0-1347**
26.5 cm

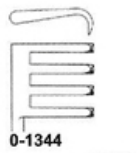

0-1344

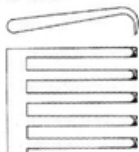

0-1346

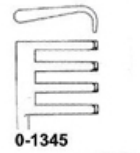

0-1345

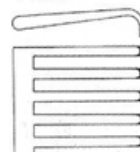

0-1347

RETRACTORS



**Mini-Langenbeck
0-1348 to 0-1351**
16 cm/6 1/4"

0-1348

0-1349

0-1350

0-1351



**Desmarres
0-1352 to 0-1357**
16 cm/6 1/4"

0-1352

0-1353

0-1354

0-1355

0-1356

0-1357

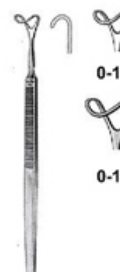

0-1358

0-1359

0-1360

0-1361

0-1358 to 0-1361
16 cm/6 1/4"

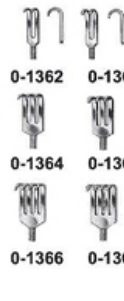

0-1362

0-1363

0-1364

0-1365

0-1366

0-1367

0-1362 to 0-1367
16 cm/6 1/4"



0-1368

0-1369

0-1368 to 0-1369
16 cm/6 1/4"

RETRACTORS

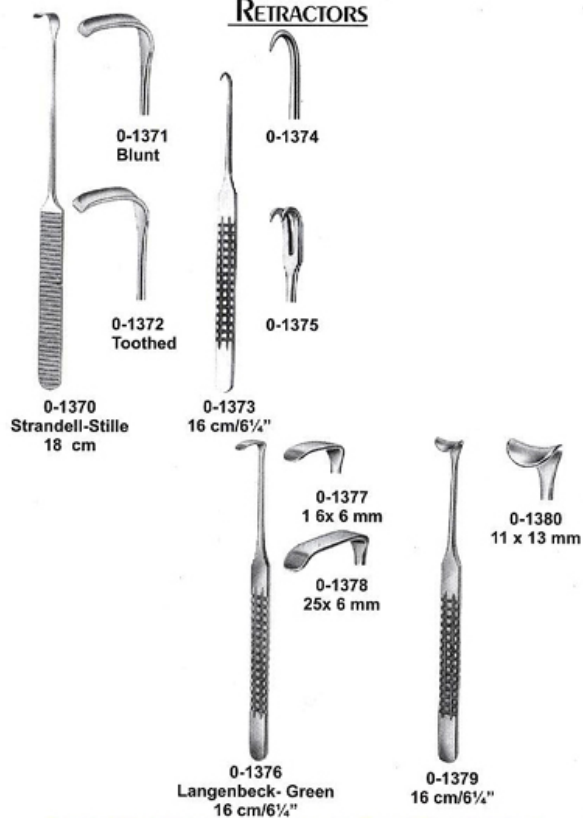

NERVE ROOT RETRACTORS

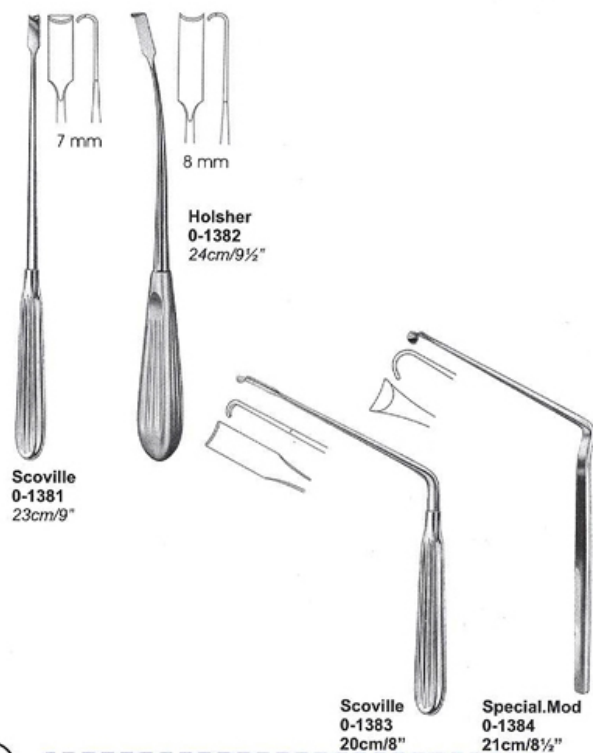

48

RETRACTORS

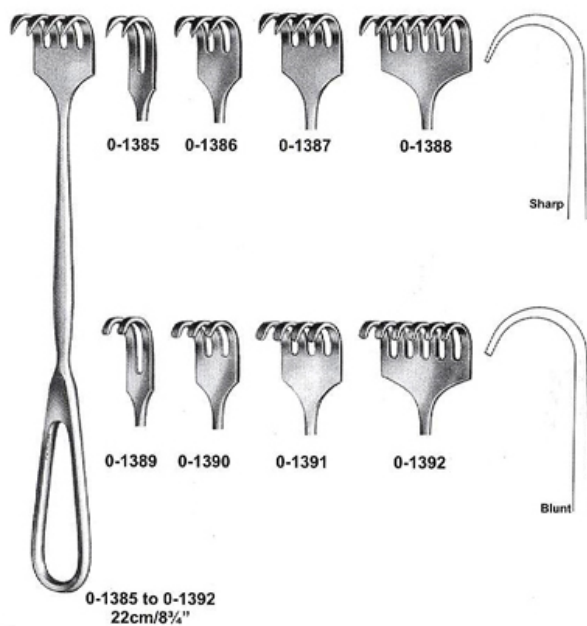

RETRACTORS

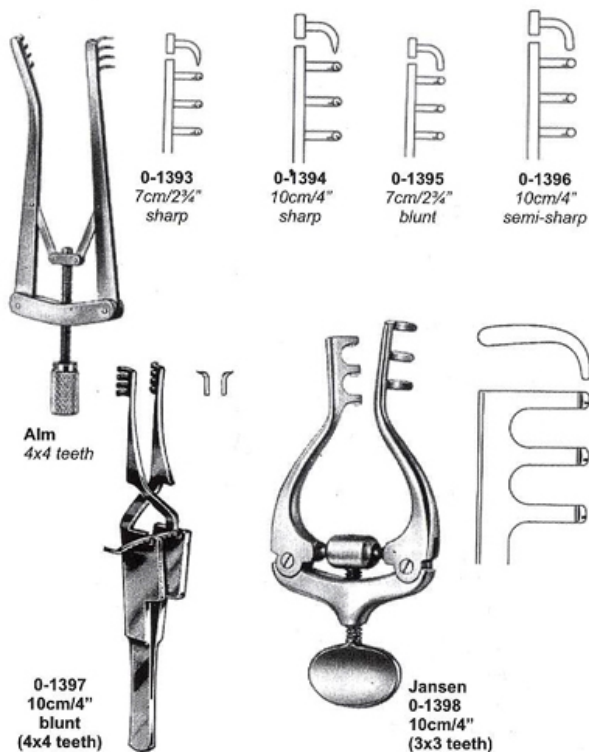

RETRACTORS

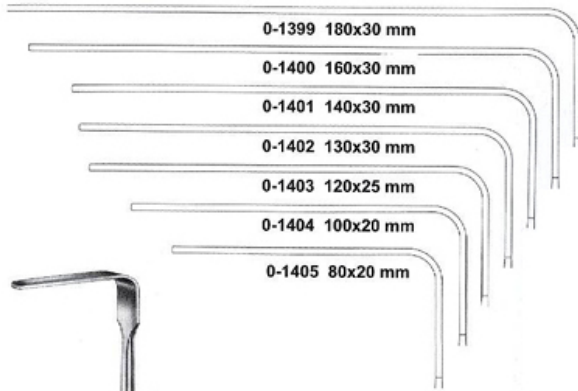

0-1399 180x30 mm

0-1400 160x30 mm

0-1401 140x30 mm

0-1402 130x30 mm

0-1403 120x25 mm

0-1404 100x20 mm

0-1405 80x20 mm



Brunner
25cm/10"

RETRACTORS

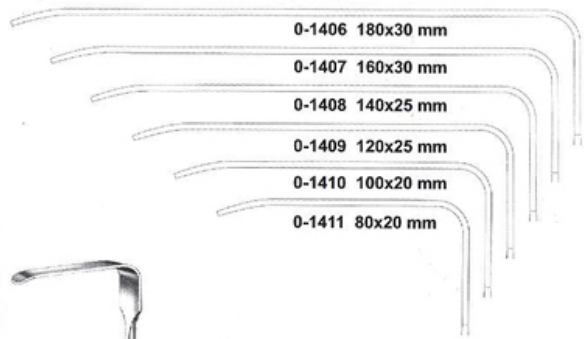

0-1406 180x30 mm

0-1407 160x30 mm

0-1408 140x25 mm

0-1409 120x25 mm

0-1410 100x20 mm

0-1411 80x20 mm



Brunner
25cm/10"

RETRACTORS

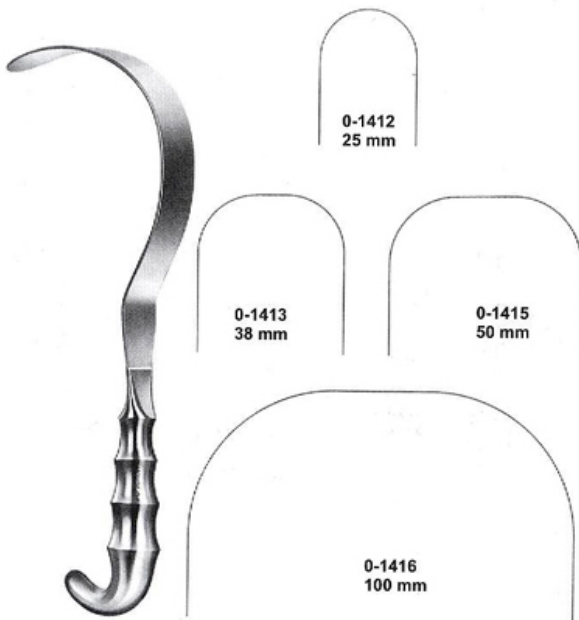

0-1412
25 mm

0-1413
38 mm

0-1415
50 mm

0-1416
100 mm

Deaver
31cm/12¼"

RETRACTORS



0-1417
127x40 mm
0-1418
127x62 mm

Harrington
32cm/12½"

RETRACTORS

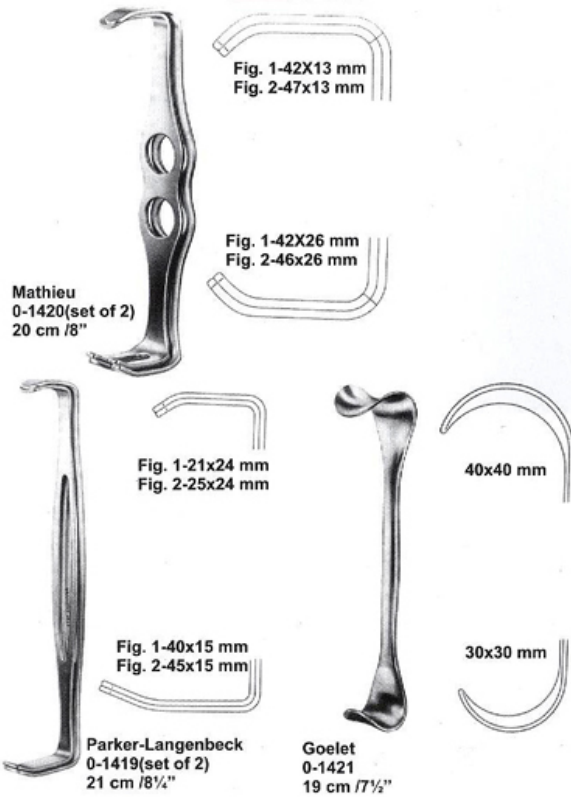

RETRACTORS

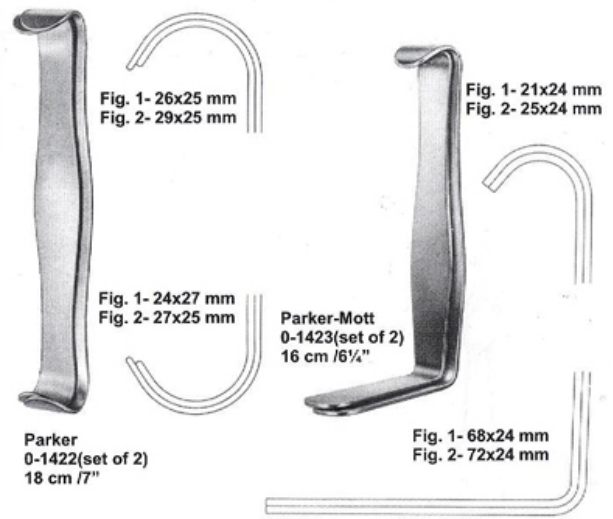

RETRACTORS

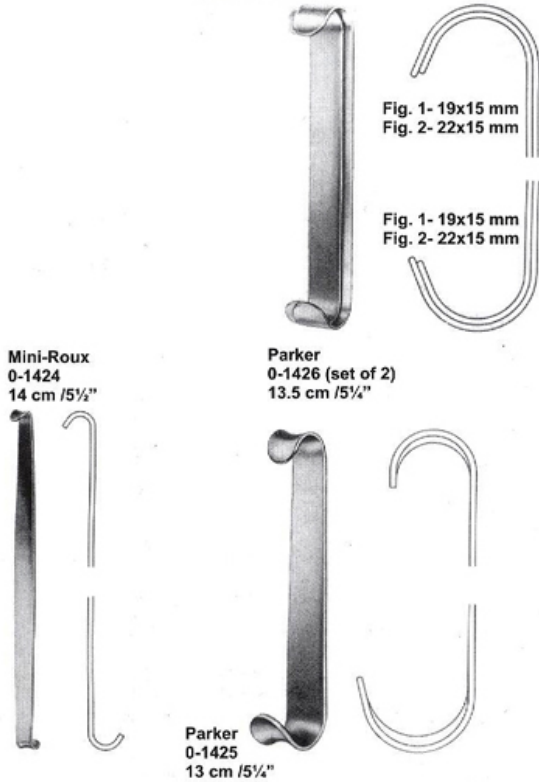

RETRACTORS

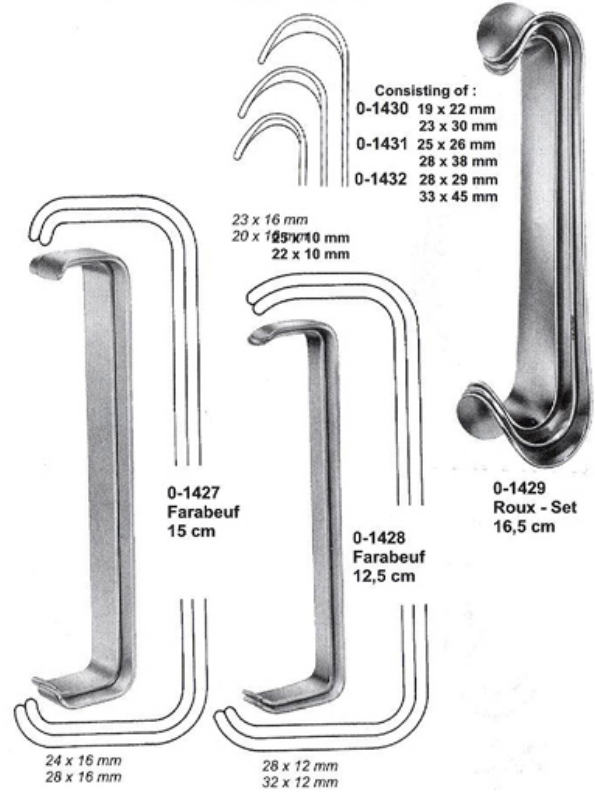

OBSTETRICAL (Midwifery) FORCEPS



De Lee
0-1433
30 cm / 12"



De Lee
0-1434 36 cm / 14"
0-1435 39 cm / 15½"



Elliot
0-1436 32 cm / 12½"
0-1437 38 cm / 15"



Mc Lean
0-1438 36 cm / 14"

OBSTETRICAL (Midwifery) FORCEPS



Simpson-Luikart
0-1439
36 cm / 14"

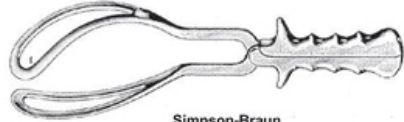

Simpson-Braun
0-1440
36 cm / 14"



Simpson
0-1441
30 cm / 12"

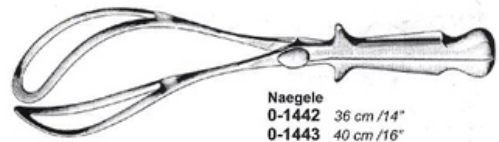

Naegele
0-1442 36 cm / 14"
0-1443 40 cm / 16"

51

OBSTETRICAL (Midwifery) FORCEPS

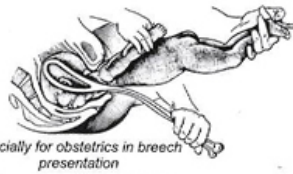

specialty for obstetrics in breech presentation



Kielland
0-1444
41 cm / 16"



Kielland-Luikart
0-1445
40 cm / 15½"



Piper
0-1446
44 cm / 17½"

RETRACTORS

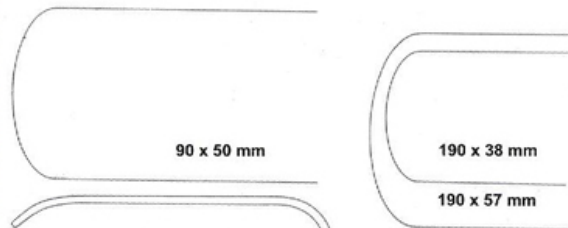

90 x 50 mm

190 x 38 mm

190 x 57 mm



Mikulicz
0-1447
26cm / 10¼"



Kelly
0-1448
27cm / 10½"

TENACULUM FORCEPS

TENACULUM FORCEPS



Schroeder
0-1449
25 cm /10"

Braun
0-1450
25 cm /10"

Duplay
0-1451
28 cm /11"



Staude-Moore
0-1452
17 cm /6 3/4"

Barrett
0-1453
18 cm /7"

Pozzi
0-1454
25,5 cm /10 1/4"

RETRACTORS, ENDOSPECULA

TENACULUM FORCEPS

With guide blades

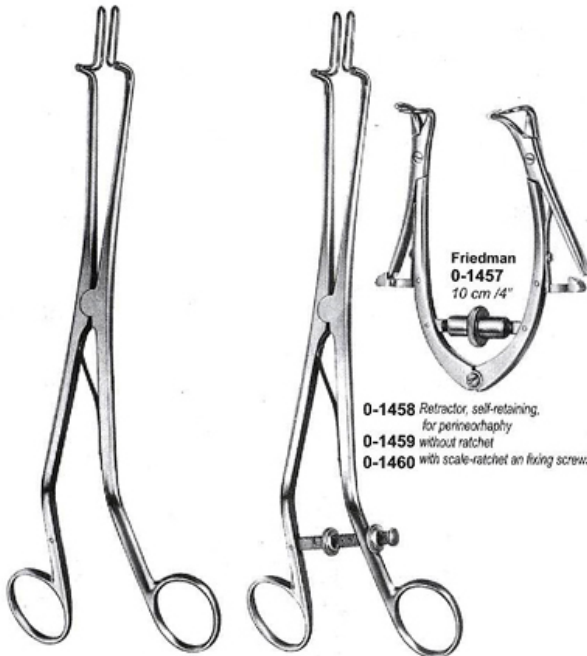

Kogan
0-1455
24 cm /9 1/2"

Kogan
0-1456
24 cm /9 1/2"

0-1458 Retractor, self-retaining,
for perineorrhaphy
0-1459 without ratchet
0-1460 with scale-ratchet on fixing screws

Friedman
0-1457
10 cm /4"

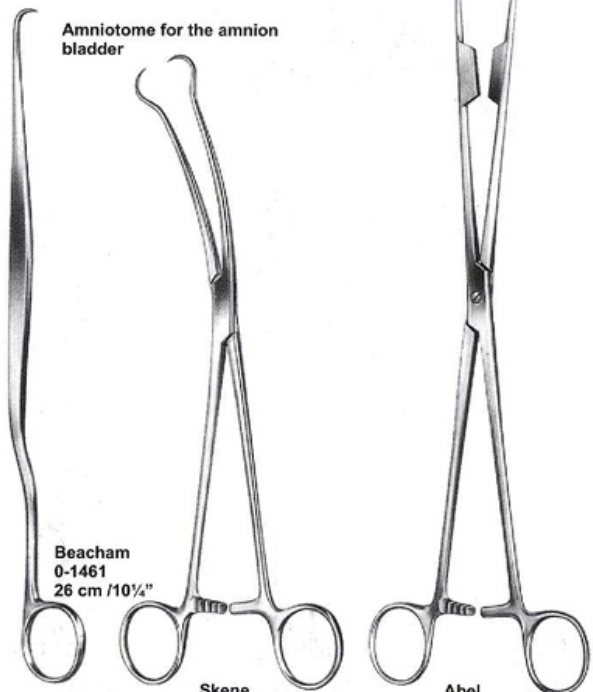

Amniotome for the amnion
bladder

Beacham
0-1461
26 cm /10 1/4"

Skene
0-1462
24 cm /9 1/2"

Abel
0-1463
27 cm /10 1/2"

DILATING BOUGIES, METAL CATHETERS

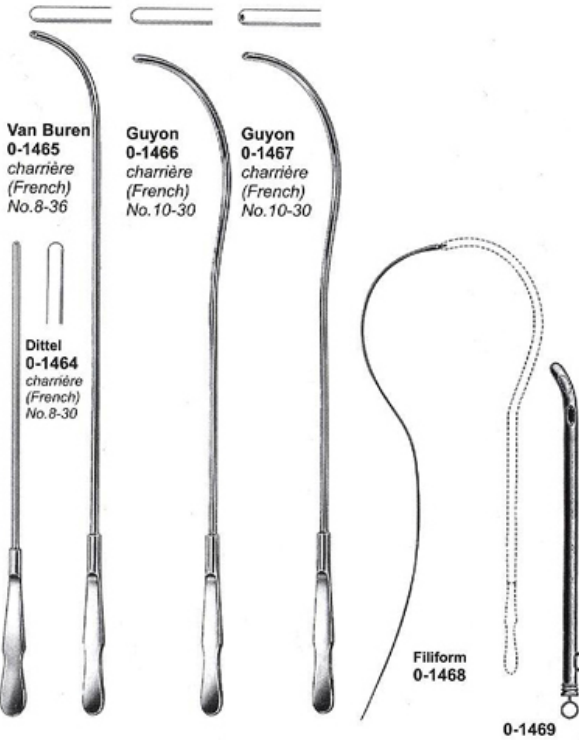

CATHETER INTRODUCING INSTRUMENTS

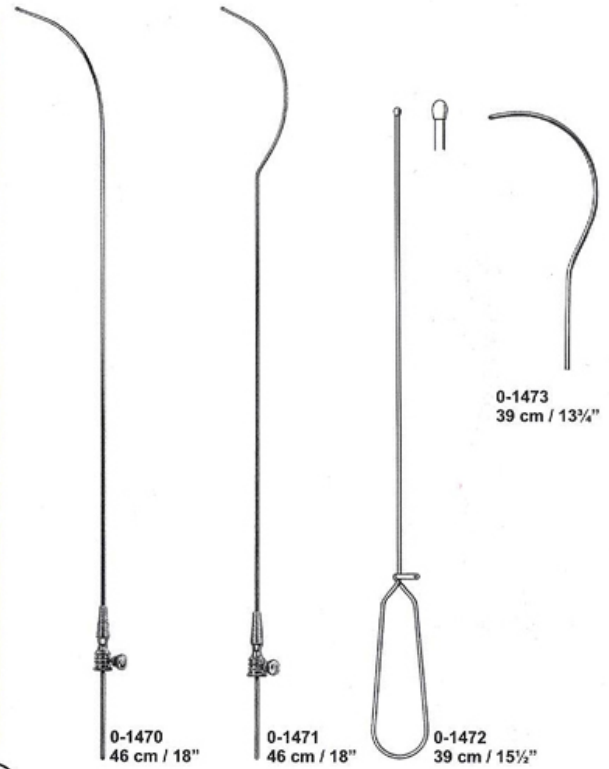

53

MEATOTOME, SECRETION SCOOPS, PENIS SEIZING FORCEPS

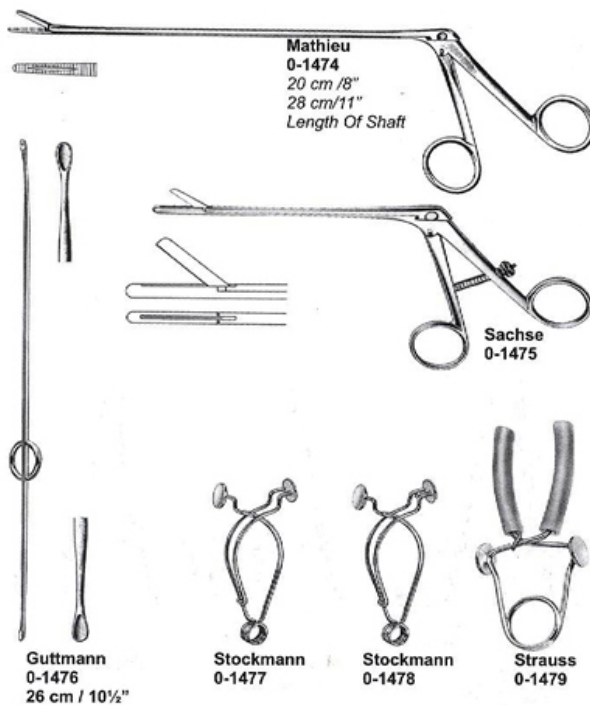

LAMINECTOMY RONGEURS

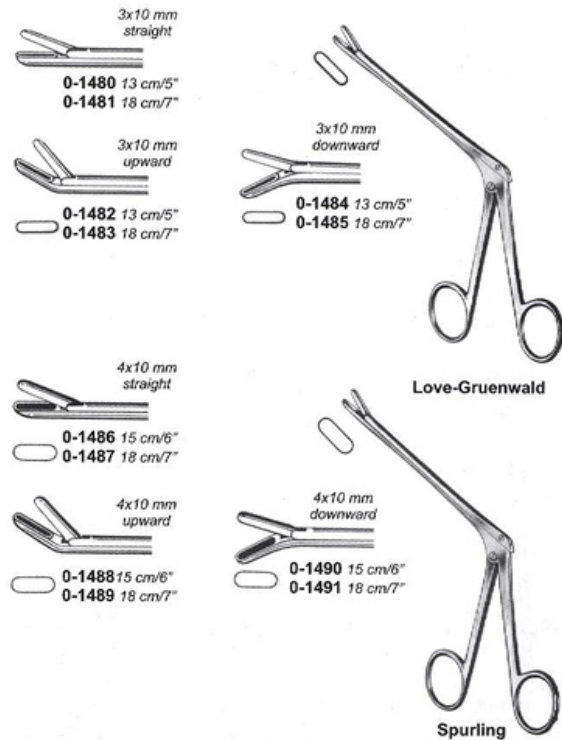

UTERINE POLYPUS FORCEPS
& TENACULUM FORCEPS

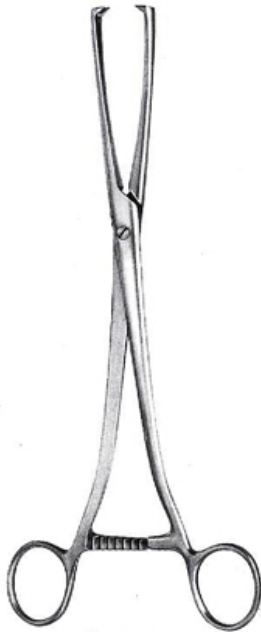

Museux
0-1492
24 cm / 9½"

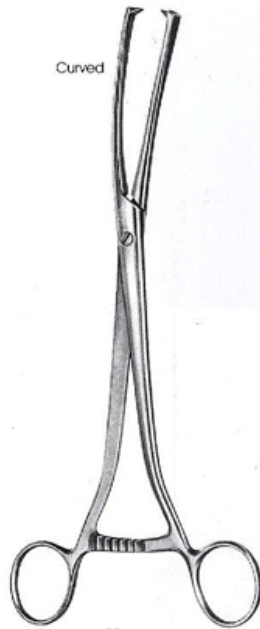

Curved

Museux
0-1493
24 cm / 9½"

UTERINE ELEVATING FORCEPS
& TENACULUM FORCEPS



Dartigues
0-1495
27 cm / 10½"



Somer
0-1496
23 cm / 9"



Collin
0-1497
25 cm / 10"

UTERINE POLYPUS FORCEPS
& TENACULUM FORCEPS

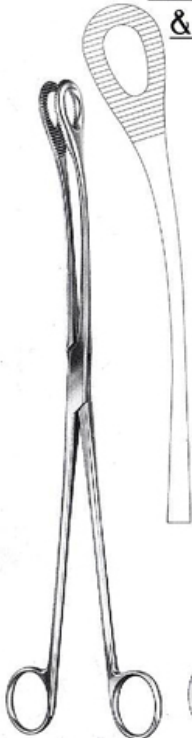

Doyen
0-1498
20 cm / 8"

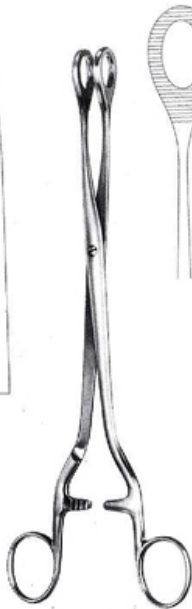

Note
0-1499
27 cm / 10½"

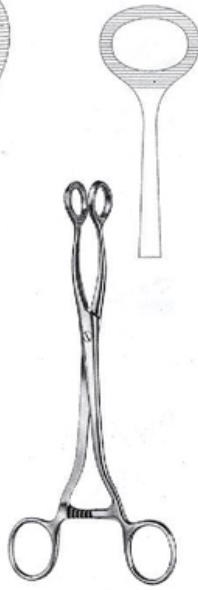

Kelly
0-1500
32 cm / 12½"

UTERINE ELEVATING FORCEPS
& TENACULUM FORCEPS

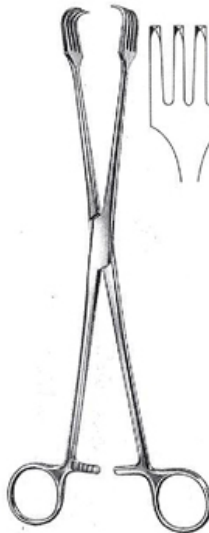

Czerny
0-1501
20,5 cm / 8¼"



Braun
0-1502
15,5 cm / 6¼"

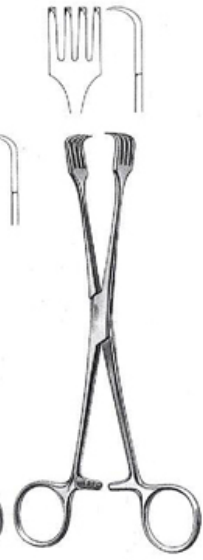

0-1503
26 cm / 10¼"

FISTULA HOOKS, CONE KNIVES

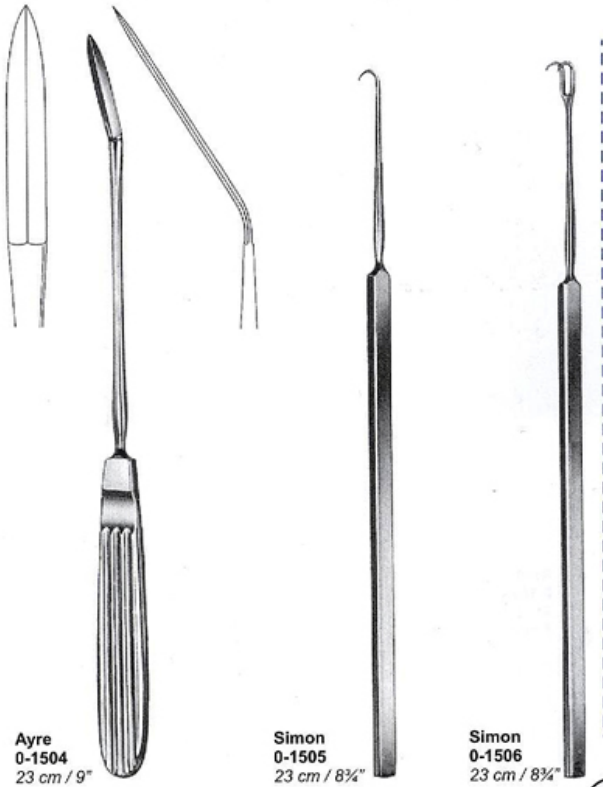

Ayre
0-1504
23 cm / 9"

Simon
0-1505
23 cm / 8 3/4"

Simon
0-1506
23 cm / 8 3/4"

TENACULUM FORCEPS & MYOMA INSTRUMENTS

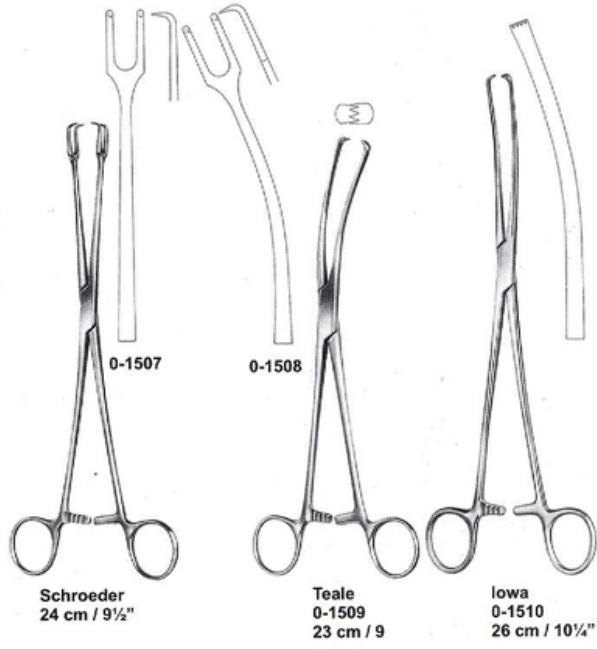

Schroeder
0-1507
24 cm / 9 1/2"

Teale
0-1509
23 cm / 9"

Iowa
0-1510
26 cm / 10 1/4"

55

TENACULUM FORCEPS

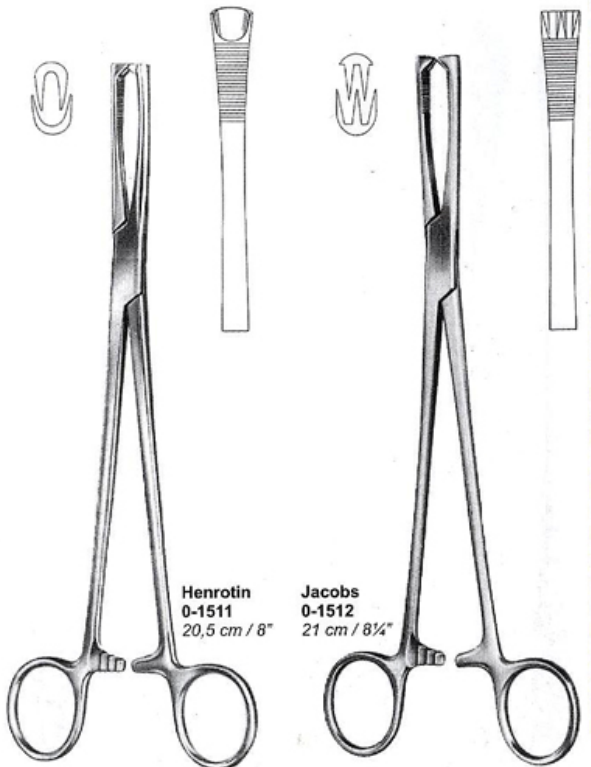

Henrotin
0-1511
20,5 cm / 8"

Jacobs
0-1512
21 cm / 8 1/4"

TENACULUM FORCEPS & MYOMA INSTRUMENTS

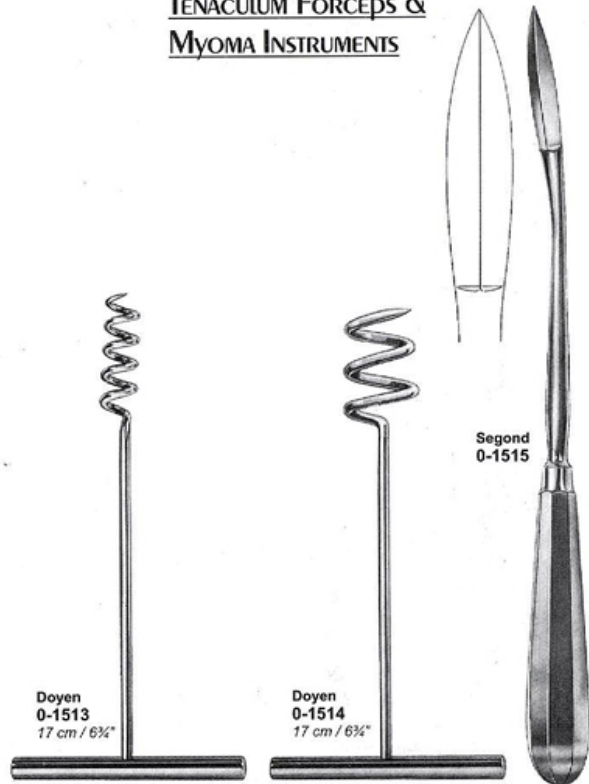

Doyen
0-1513
17 cm / 6 3/4"

Doyen
0-1514
17 cm / 6 3/4"

Segond
0-1515

UTERINE SOUNDS AND DEPRESSORS



Sims
0-1516
32 cm / 12½"

Martin
0-1517
32 cm / 12½"

Collin
0-1518
28 cm / 11"

Valleix
0-1519
25 cm / 10"

Braun
0-1520
28 cm / 11"

SUCTION BIOPSY CURETTES

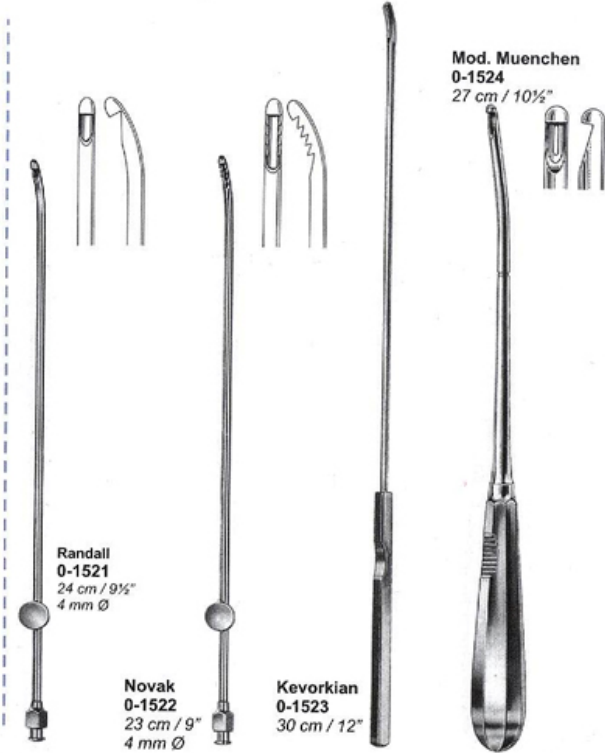

Randall
0-1521
24 cm / 9½"
4 mm Ø

Novak
0-1522
23 cm / 9"
4 mm Ø

Kevorkian
0-1523
30 cm / 12"

Mod. Muenchen
0-1524
27 cm / 10½"

56

TRANSCERVICAL ASPIRATION INSTRUMENT

Advantages

- Optimal visibility with ultrasound.
- Less traumatic because of the bulbshaped end.
- Even when strongly flexed the obturator is extremely easy to remove.
- After removal of the obturator the catheter is still easy to manipulate in all directions.
- The placental area is easy accessible due to softness of the catheter, even in case of an unfavorable position of the uterus.
- Cost is minimal due to durability and reusability.

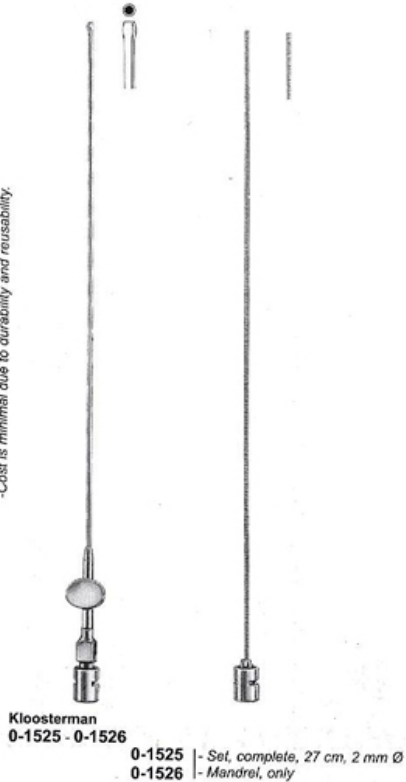

Kloosterman
0-1525 - 0-1526

0-1525 - Set, complete, 27 cm, 2 mm Ø
0-1526 - Mandrel, only

OVUM CURETTES, ABORTION SCOOPS, Clamps Umbilicales

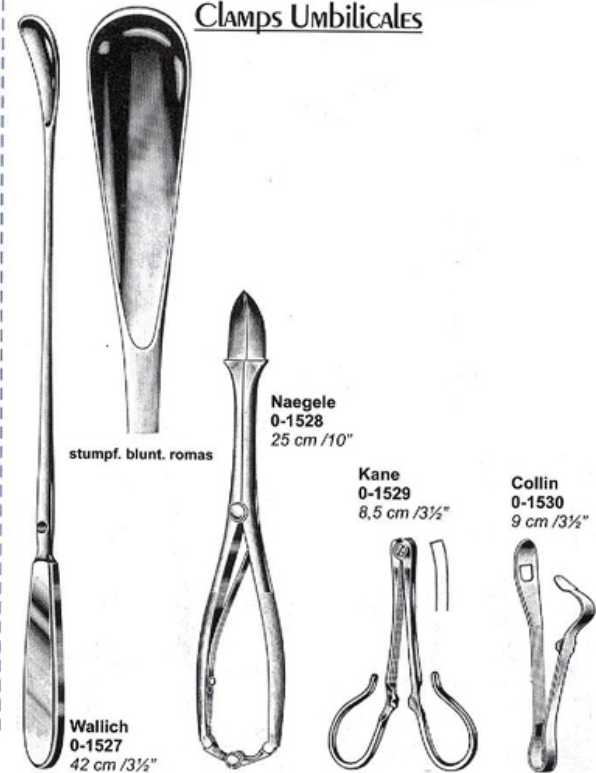

stumpf. blunt. romas

Wallich
0-1527
42 cm / 3½"

Naegele
0-1528
25 cm / 10"

Kane
0-1529
8,5 cm / 3½"

Collin
0-1530
9 cm / 3½"

PELVIMETERS



Martin
0-1531
34 cm / 13½"
cm / inch scale



Collin
0-1532
35 cm / 13¾"
cm scale



Breisky
0-1533
33 cm / 13"
cm / inch scale

OVUM CURETTES, ABORTION SCOOPS



toothed back



14½ mm



18 mm



21 mm

0-1534

0-1535

0-1536

stumpf, blunt, romas



Cuzzi
30 cm / 12"



Pestalozza
0-1537
30 cm / 12"

57

UTERINE SCOOPS

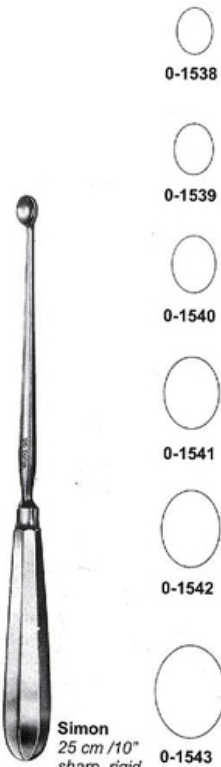

Simon
25 cm / 10"
sharp, rigid



0-1538

0-1539

0-1540

0-1541

0-1542

0-1543



Schroeder
30 cm / 10"
sharp, rigid



0-1544

0-1545

0-1546

0-1547

0-1548

0-1549

UTERINE SCOOPS

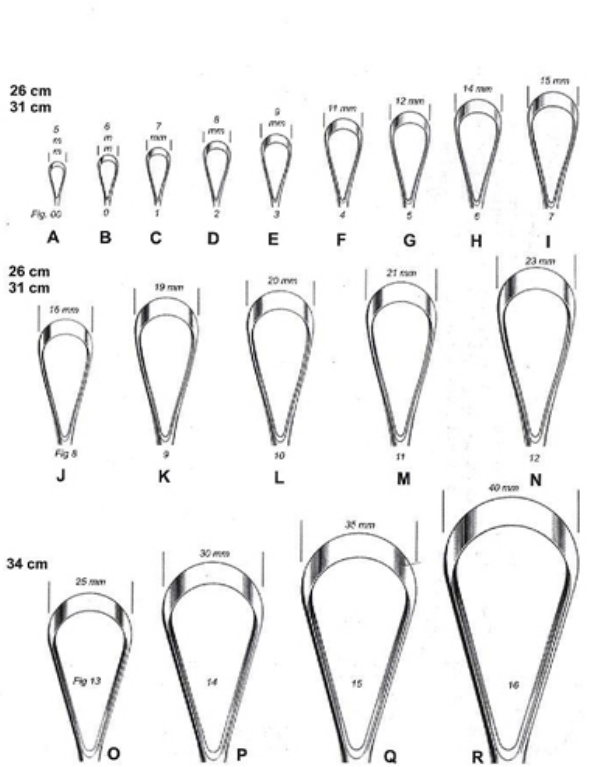

26 cm
31 cm

5 mm

6 mm

7 mm

8 mm

9 mm

11 mm

12 mm

14 mm

15 mm

16 mm

19 mm

20 mm

21 mm

23 mm

25 mm

30 mm

35 mm

40 mm

Fig. 00

A

B

C

D

E

F

G

H

I

Fig. 8

J

K

L

M

N

Fig. 13

O

P

Q

R

GALL STONE FORCEPS, CATCHERS,
AND SCOOPS

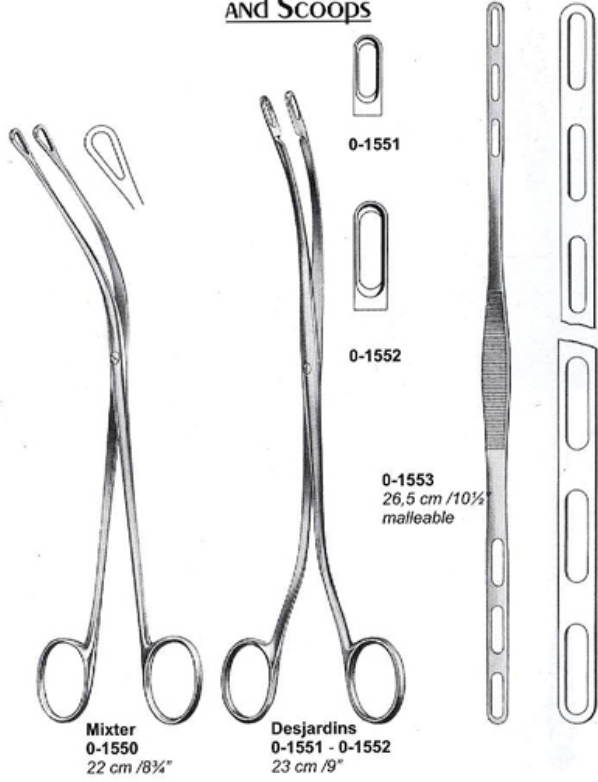

NEPHROSTOMY FORCEPS

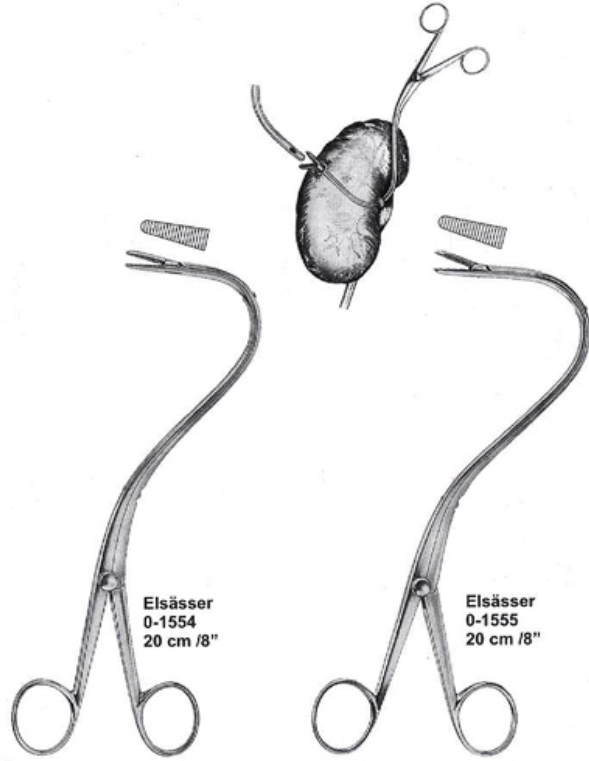

58

KIDNEY FORCEPS, CATHETER INTRODUCERS



GALL STONE FORCEPS

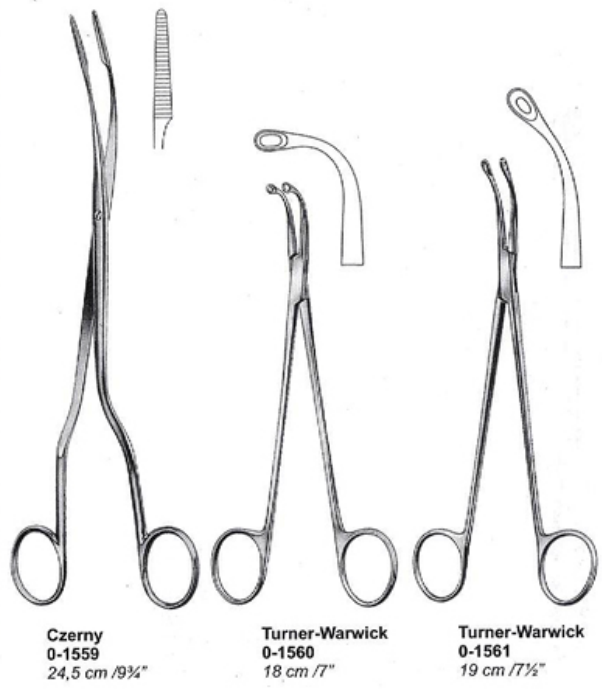

GALL STONE SCOOPS



GALL STONE SCOOPS

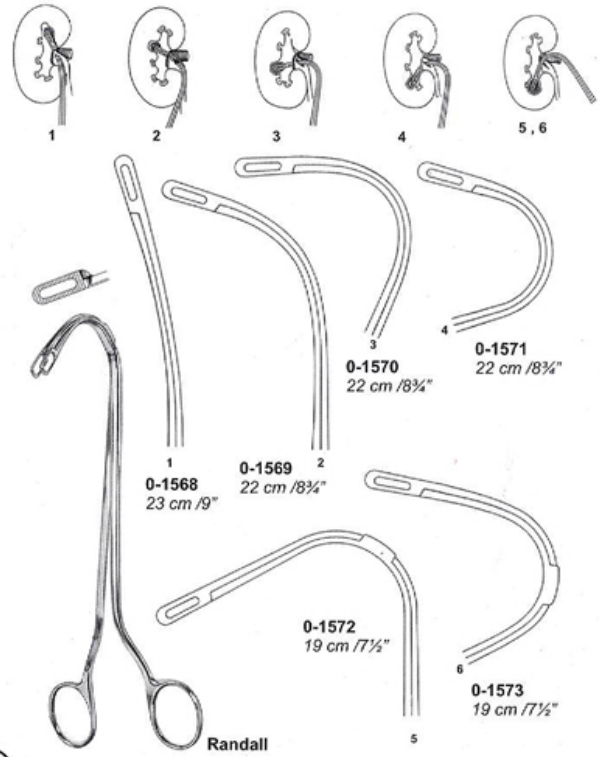

GALL STONE SCOOPS

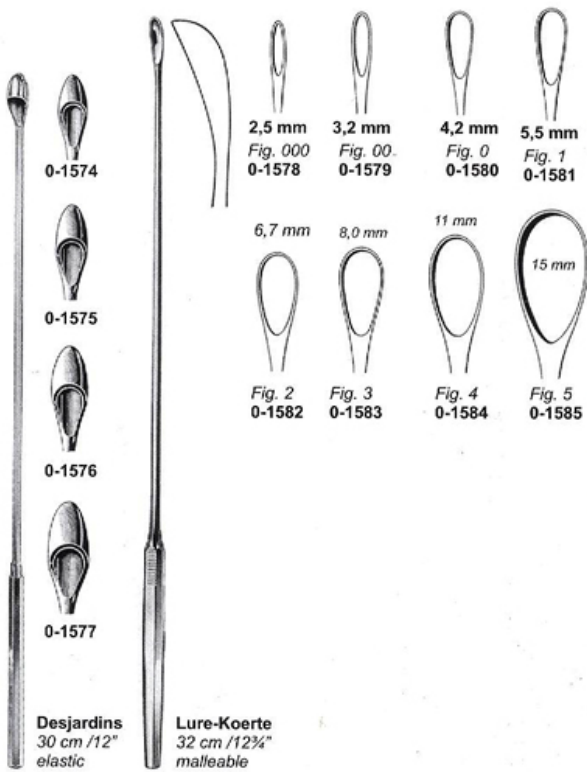

GALL STONE PROBES, GALL DUCT DILATORS

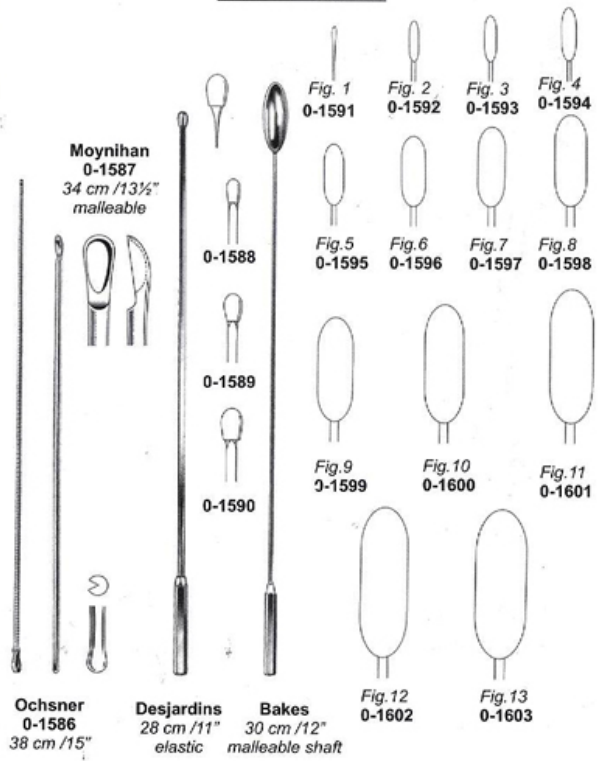

GALL STONE FORCEPS

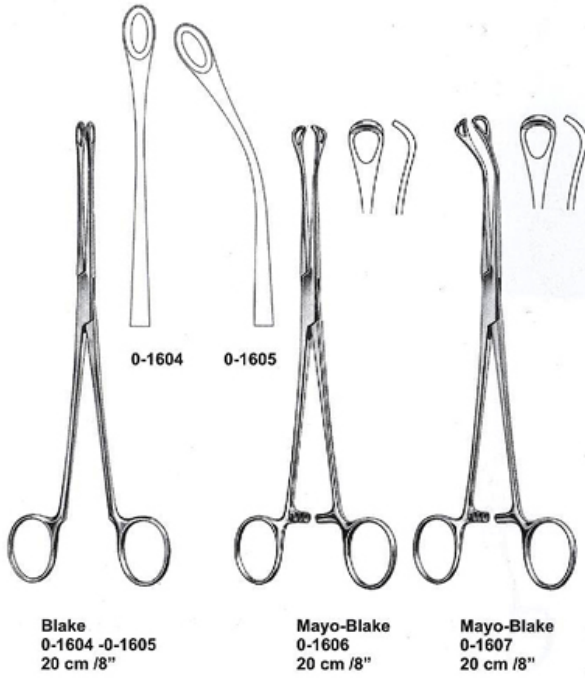

Scalp Flap Forceps, Elevating Spoon

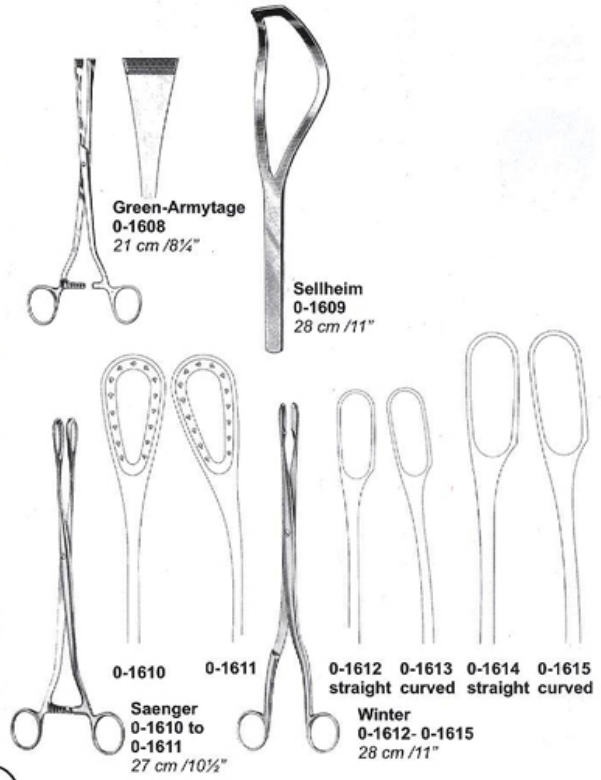

GALL STONE FORCEPS

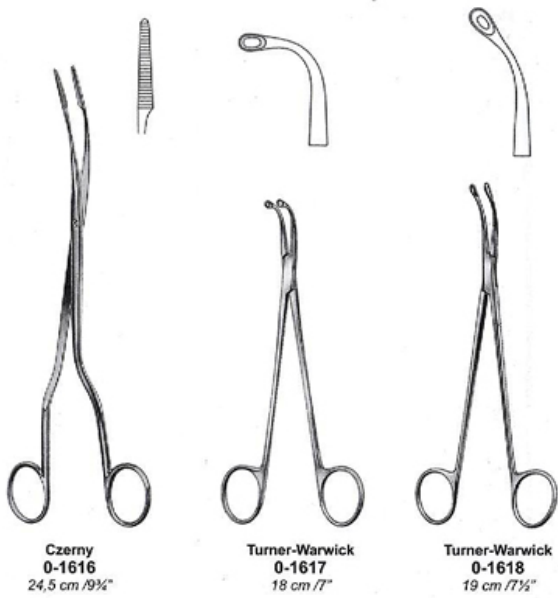

URETER CALCULUS FORCEPS

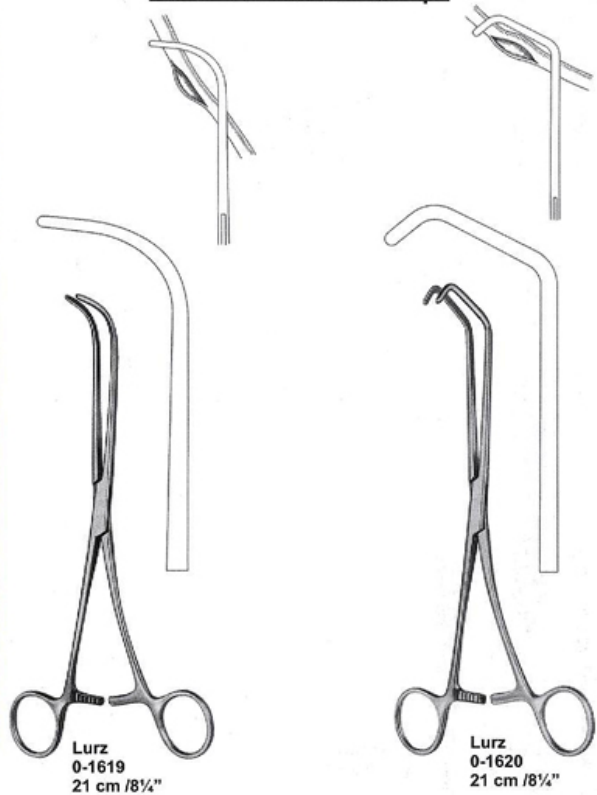

**RECTAL BIOPSY SPECIMEN FORCEPS,
HAEMORRHOIDAL(Pile) FORCEPS**

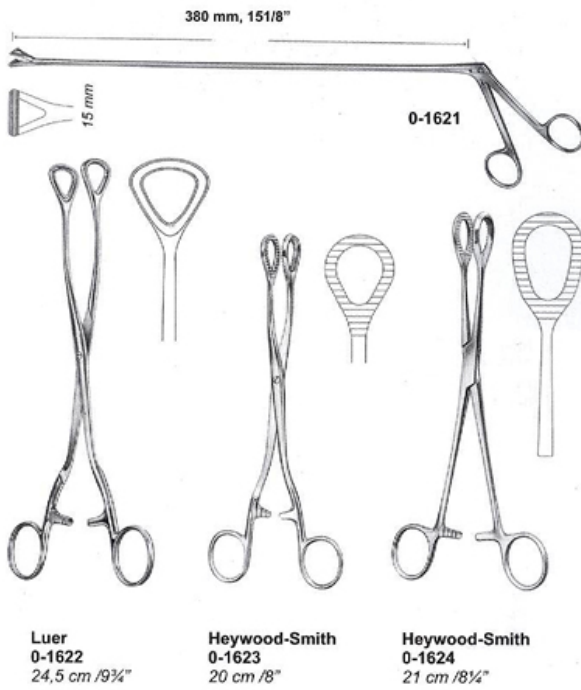

PROSTATECTOMY INSTRUMENTS

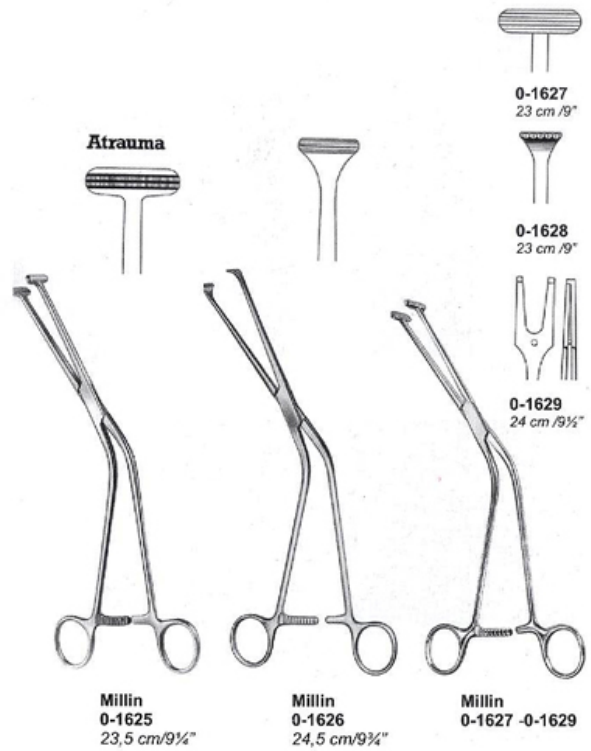

61

CERVICAL BIOPSY AND SPECIMEN FORCEPS

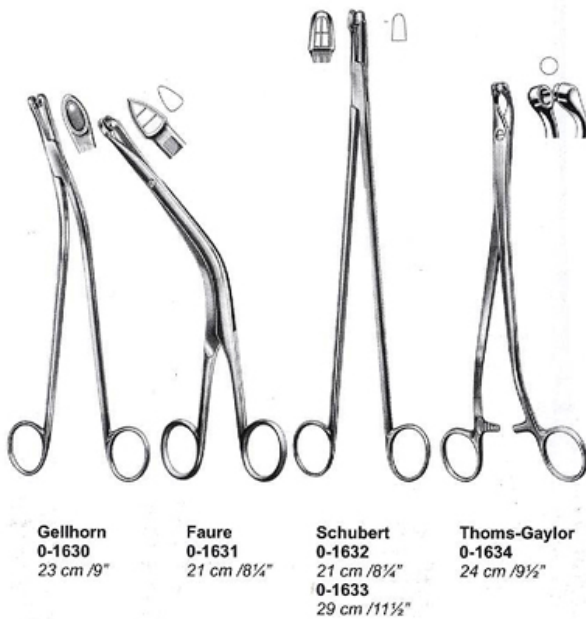

CERVICAL BIOPSY AND SPECIMEN FORCEPS

Its S-shaped construction allows clear view and sharply-delineated excisions.

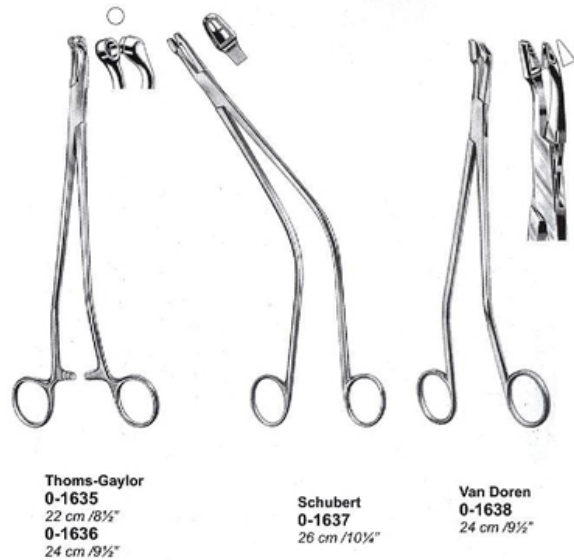

UTERINE DilATORS

0-1639
Set of 8 dilators
3.0/4.0 - 17.0/18.0 mmØ,
in boilable canvas roll



0-1640
Set of 5 dilators

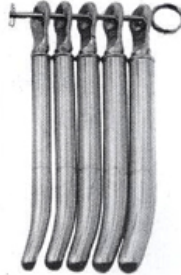

0-1641
Set of 13 dilators
1.0/2.0 - 25.0/26.0 mmØ,
in metal case with hinged lid



0-1642
Set of 15 dilators

UTERINE DilATORS

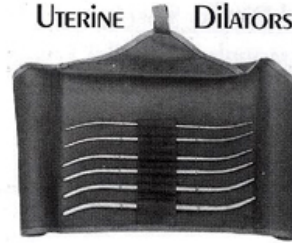

Hank
0-1643
Set of 6

American
Scoble

Hank
0-1644
to
0-1649



Hank
Fig. 9/10 **0-1644** 4,5-5 mm
Fig. 11/12 **0-1645** 5,5/6 mm
Fig. 13/14 **0-1646** 6,5/7 mm
Fig. 15/16 **0-1647** 7,5/8 mm
Fig. 17/18 **0-1648** 8,5/9 mm
Fig. 19/20 **0-1649** 9,5/10 mm

Hank
0-1650
Set of 6

62

UTERINE DilATORS

0-1651 Set of 14 dilators
(4,0 - 17,0 Ø), in metal case with hinged lid

0-1652 Set of 26 dilators
(1,0 - 26,0 mm Ø), in metal case hinged lid

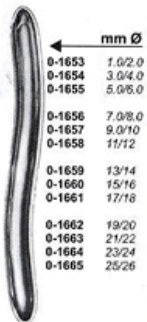

Pieces per set	Set
14	0-1666
26	0-1667

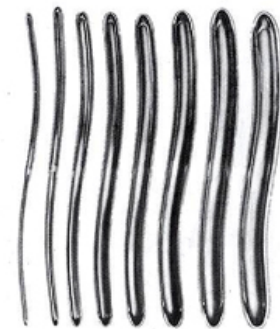

0-1668
Set of 8 dilators 3.0/4.0 - 17.0/18.0 mmØ

0-1669
Set of 13 dilators 1.0/2.0 - 25.0/26.0 mmØ

UTERINE

Sharp

Blunt

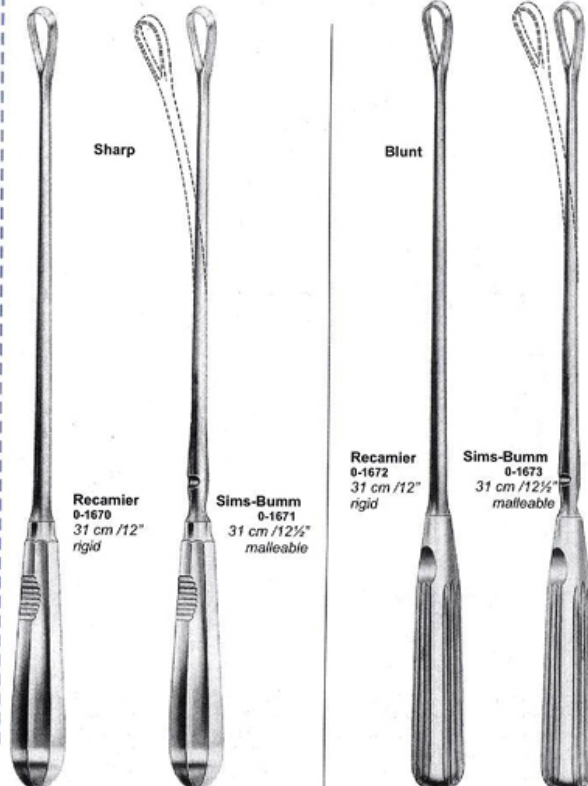

Recamier
0-1670
31 cm /12"
rigid

Sims-Bumm
0-1671
31 cm /12½"
malleable

Recamier
0-1672
31 cm /12"
rigid

Sims-Bumm
0-1673
31 cm /12½"
malleable

**ATRAUMA Sigmoid
ANASTOMOSIS FORCEPS**

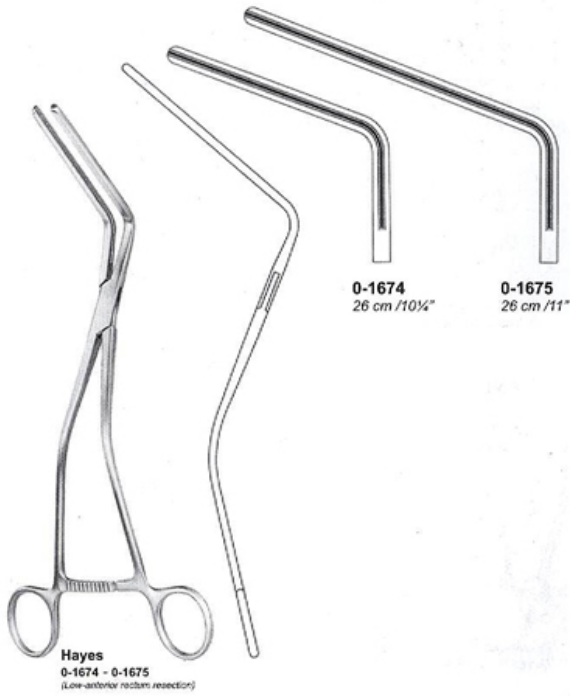

**ATRAUMA Sigmoid
ANASTOMOSIS FORCEPS**

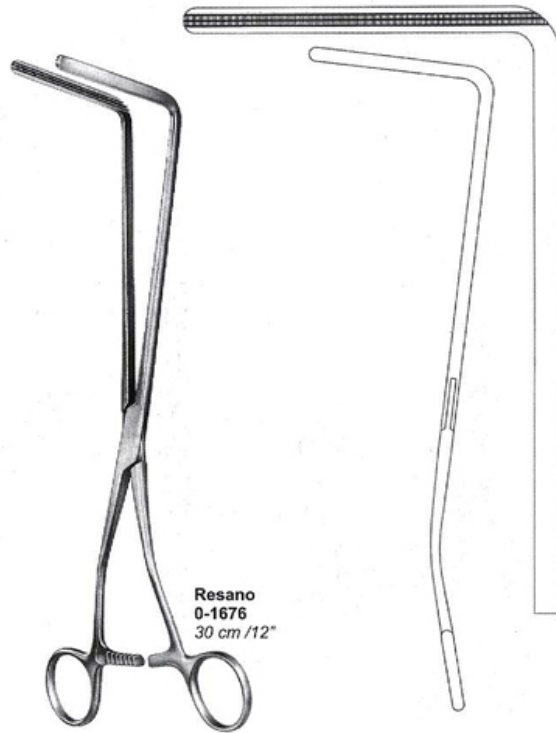

63

**ATRAUMA Sigmoid
ANASTOMOSIS FORCEPS**



**ATRAUMA INTESTINAL AND STOMACH CLAMP
FORCEPS, WITH MARTIN SERRATIONS**

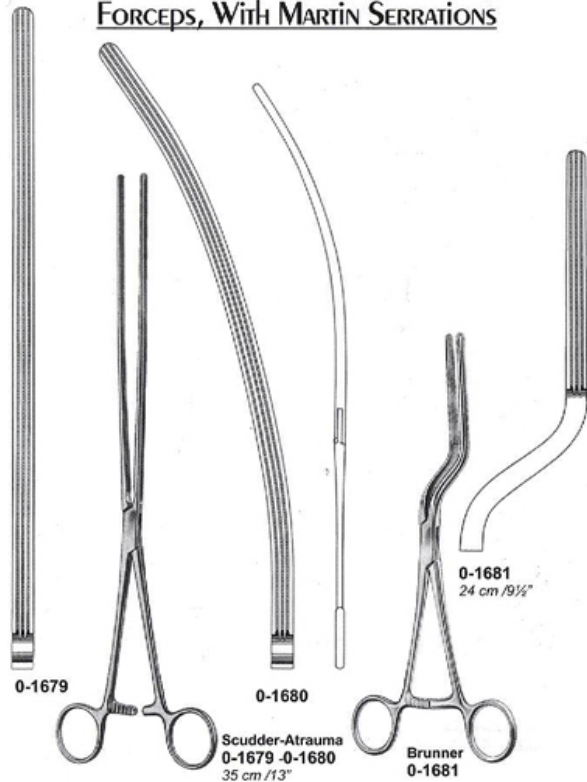

**ATRAUMA INTESTINAL AND STOMACH CLAMP
FORCEPS, WITH MARTIN SERRATIONS**

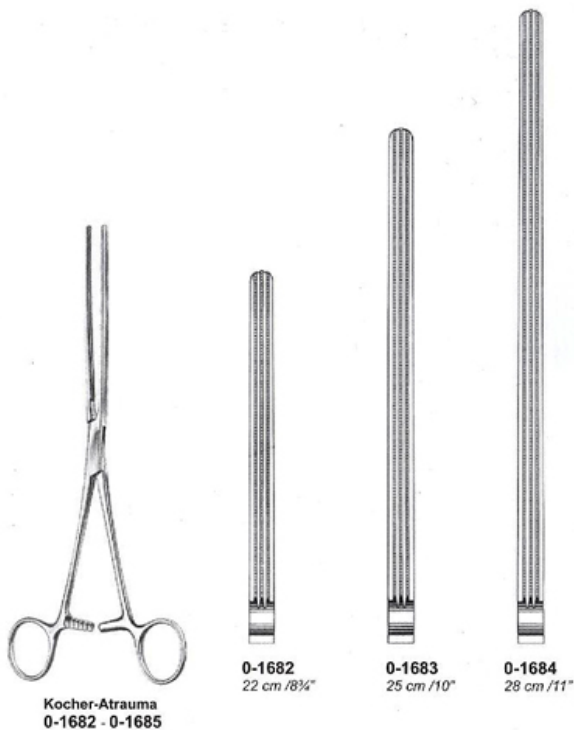

**ATRAUMA INTESTINAL AND STOMACH CLAMP
FORCEPS, WITH MARTIN SERRATIONS**

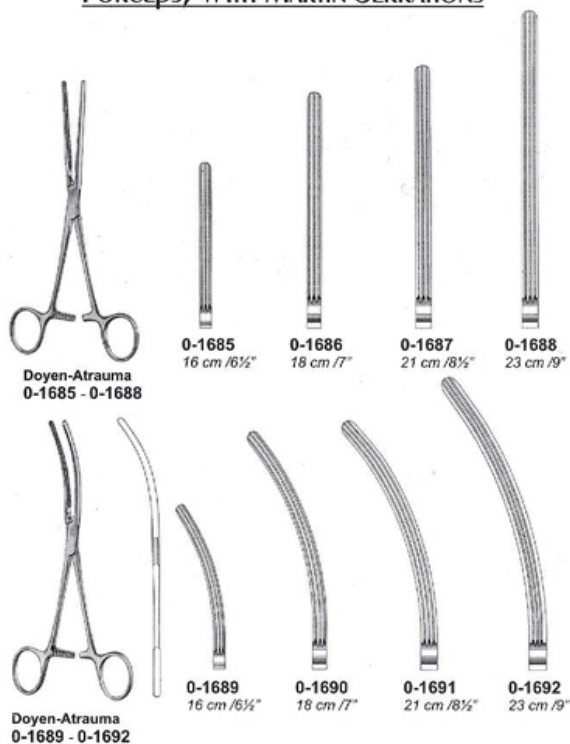

**ATRAUMA INTESTINAL AND STOMACH CLAMP
FORCEPS, WITH MARTIN SERRATIONS**

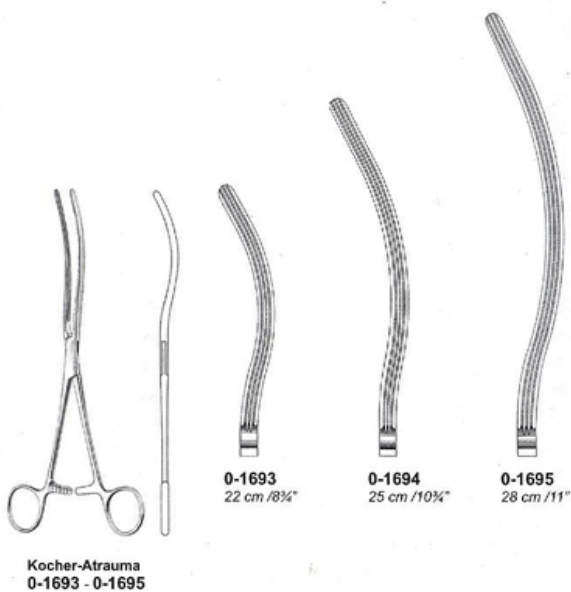

**ATRAUMA INTESTINAL AND STOMACH CLAMP
FORCEPS, WITH MARTIN SERRATIONS**

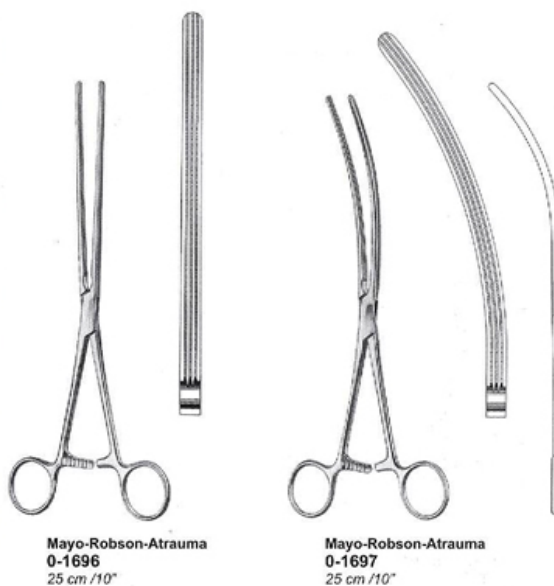

ASPIRATING CURETTES



SEPTUM COMPRESSION FORCEPS

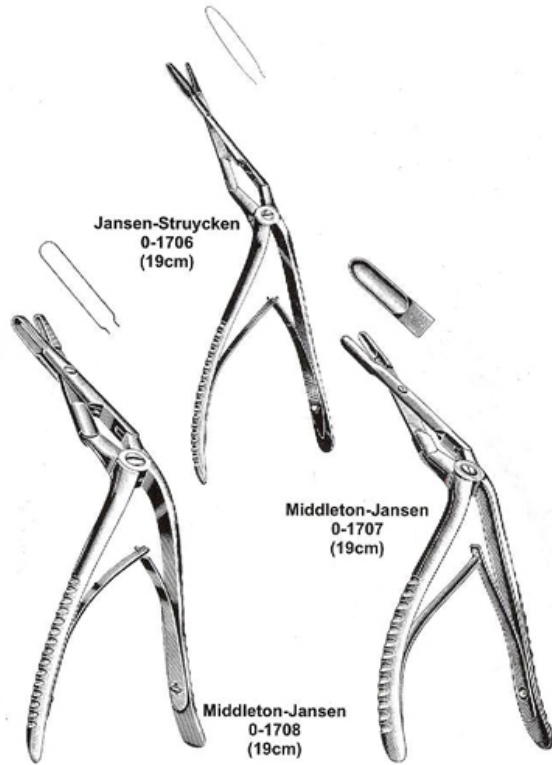

65

BRONCHUS FORCEPS, LIGATURE FORCEPS

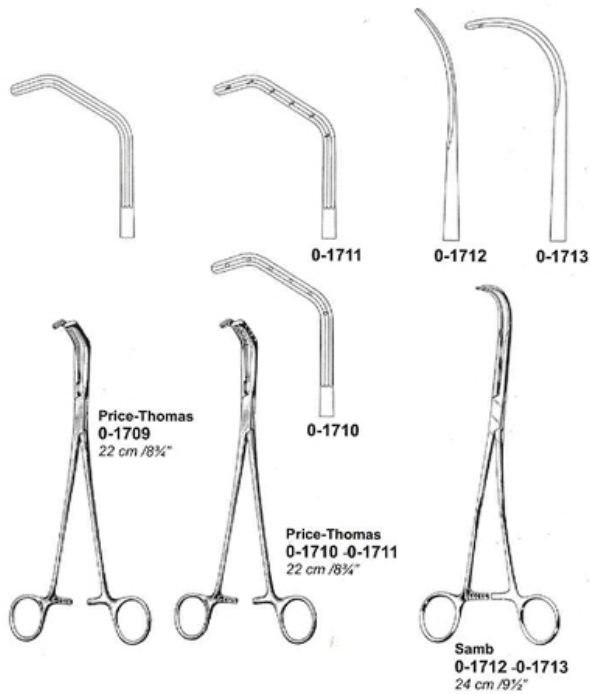

LAMINA SPREADERS

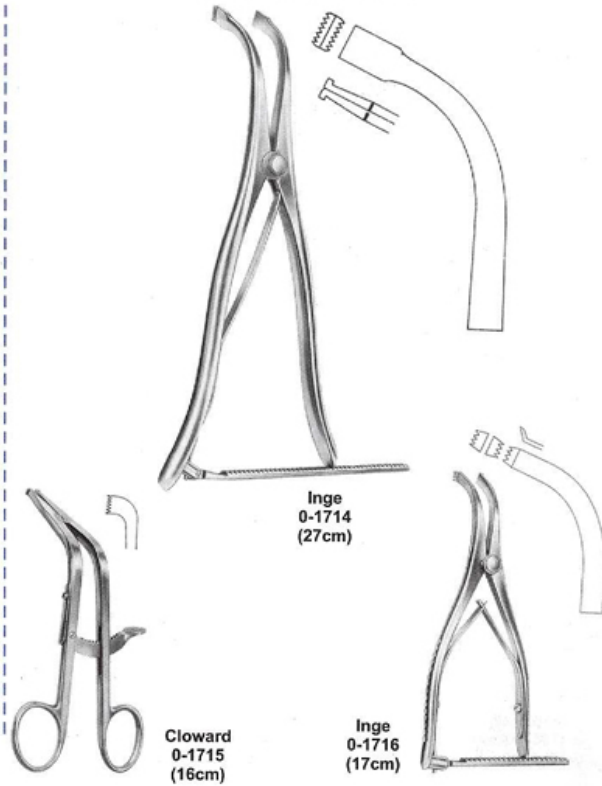

ANTRUM PUNCH FORCEPS
SPHENOID PUNCHES



Hajek-Claus
0-1717
(20cm)

Kerrison
0-1718 to 0-1720
(20cm)

4x4 mm 5x5 mm 6x6 mm
0-1718 0-1719 0-1720
(4 mm) (5 mm) (6 mm)

BONE PUNCHES

ATTICUS PUNCHES



Ultra fines

Beyer
0-1721
16 cm/6 1/4"

Beyer
0-1722
19 cm/7 1/2"

Citelli
17 cm/6 3/4"
0-1723 2 mm
0-1724 3 mm

Clips Applying FORCEPS



OlivecronToennis
(Scoville)
0-1725

McKenzie
0-1726 (15cm)
0-1727 (19cm)

McKenzie
0-1728 (15cm)
0-1729 (19cm)

Raney
0-1730

TISSUE & ORGAN HOLDING FORCEPS

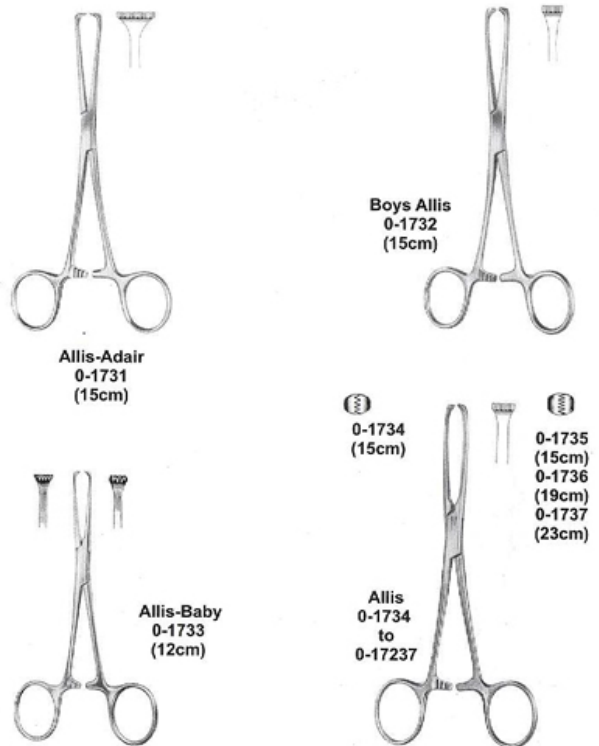

Allis-Adair
0-1731
(15cm)

Boys Allis
0-1732
(15cm)

0-1734
(15cm)

0-1735
(15cm)
0-1736
(19cm)
0-1737
(23cm)

Allis-Baby
0-1733
(12cm)

Allis
0-1734
to
0-17237

CERVICAL BIOPSY & SPECIMEN FORCEPS

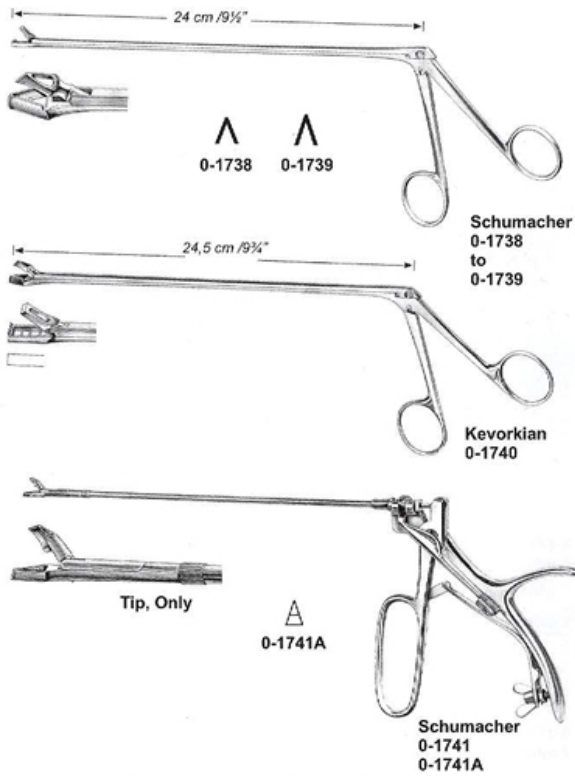

CERVICAL BIOPSY & SPECIMEN FORCEPS

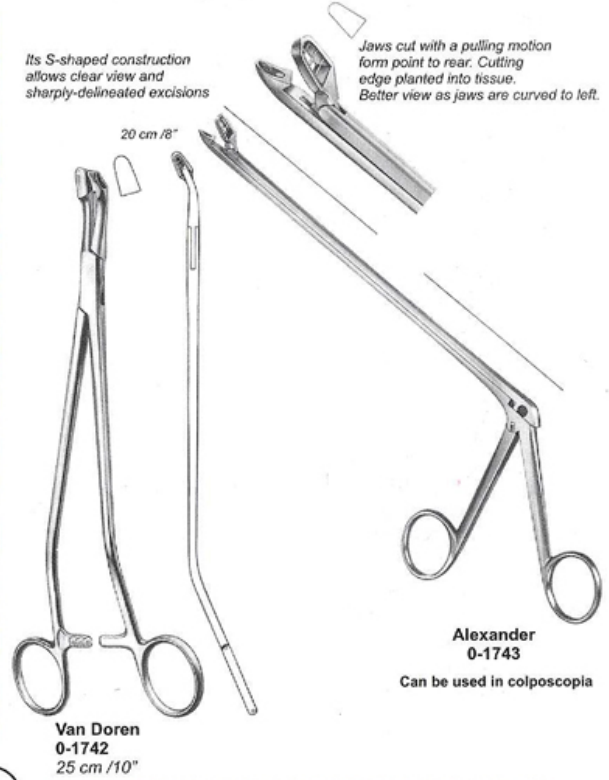

67

PUNCHES & RONGEUR

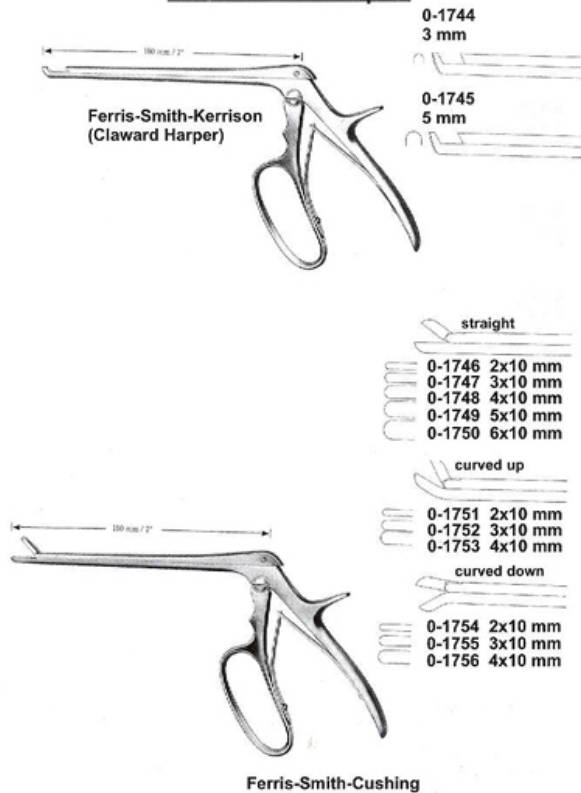

CERVICAL BIOPSY & SPECIMEN FORCEPS

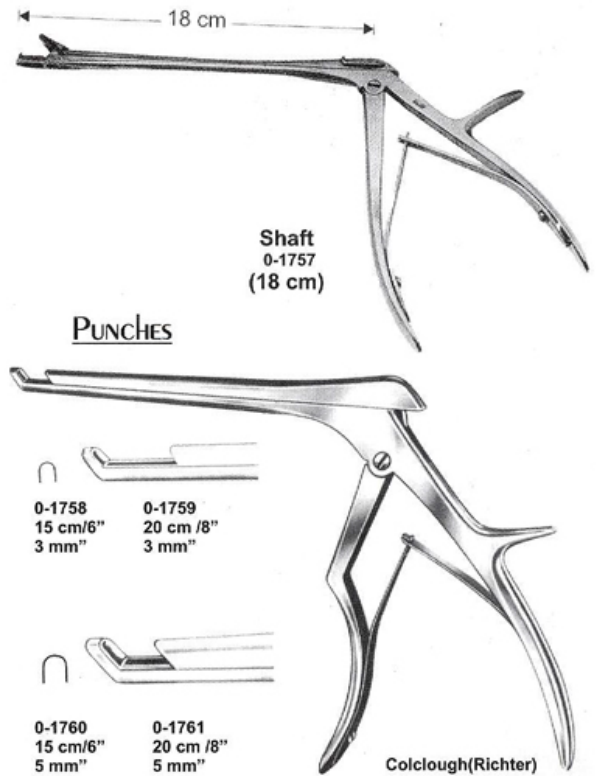

LAMINECTOMY PUNCHES

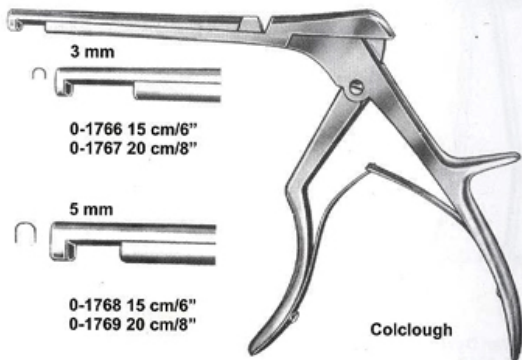
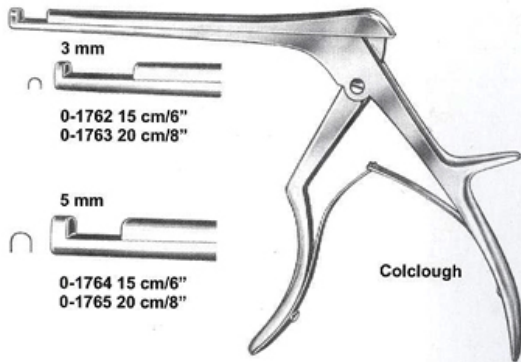

LAMINECTOMY PUNCHES

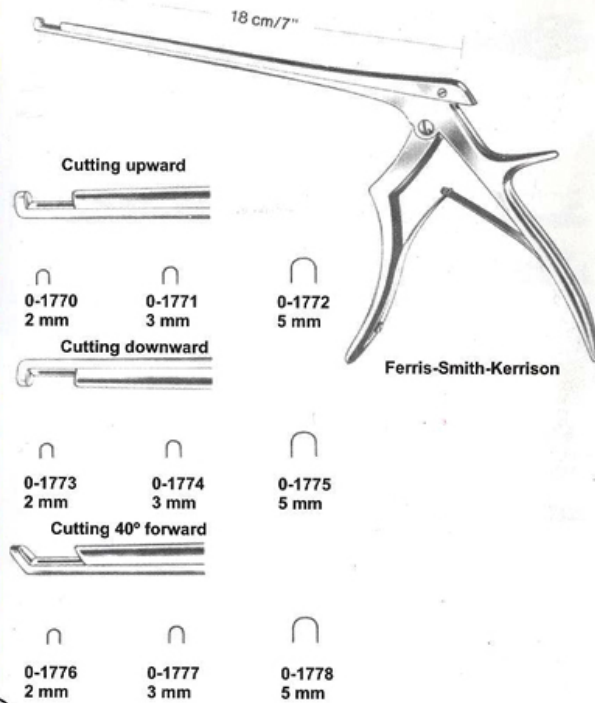

68

LAMINECTOMY RONGEUR

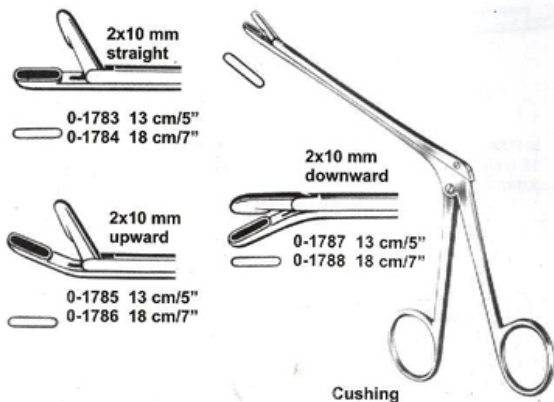
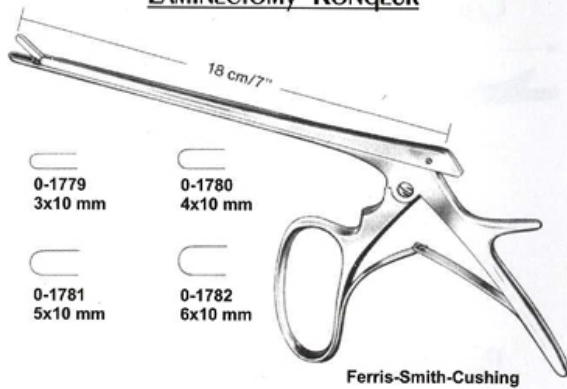

PUNCHES

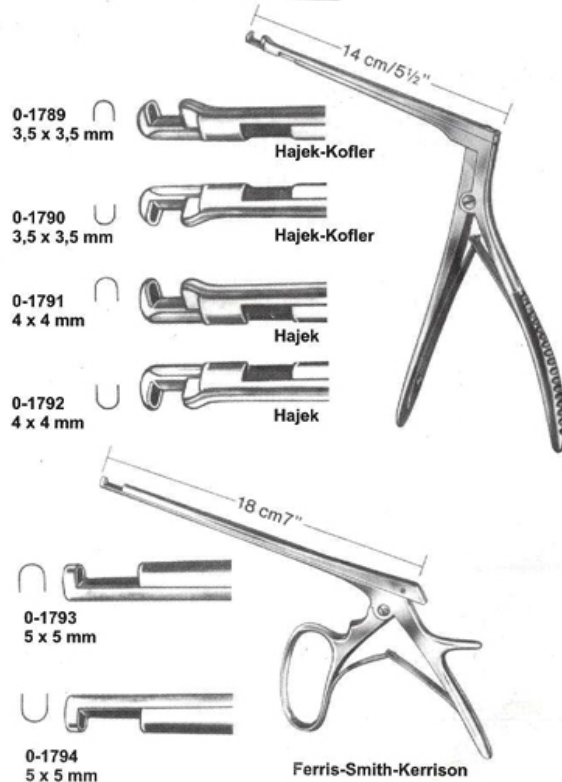

BONE CURETTES

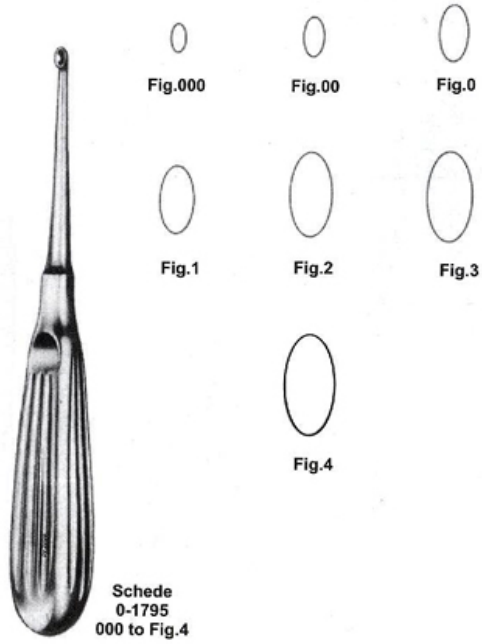

BONE CURETTES

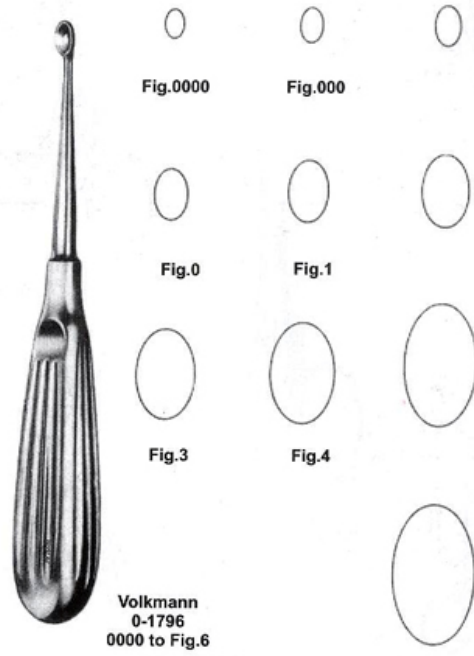

BONE CURETTES

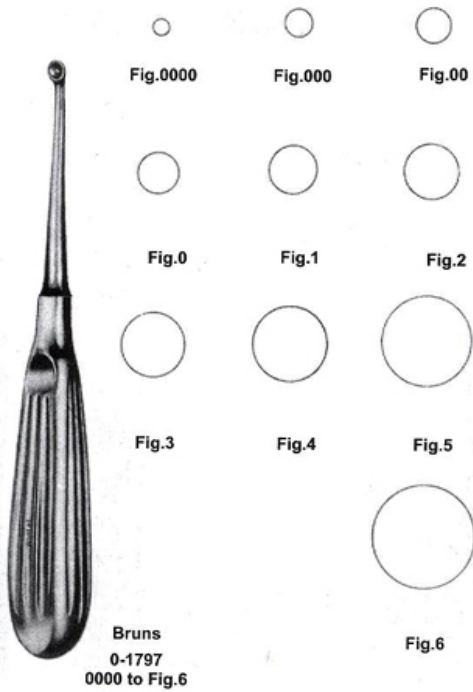

BONE CURETTES

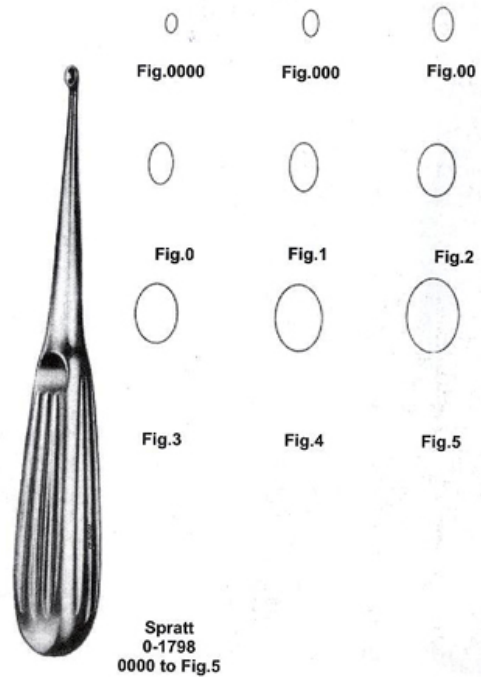

PLASTER SHEARS, BANDAGE & Utility Scissors

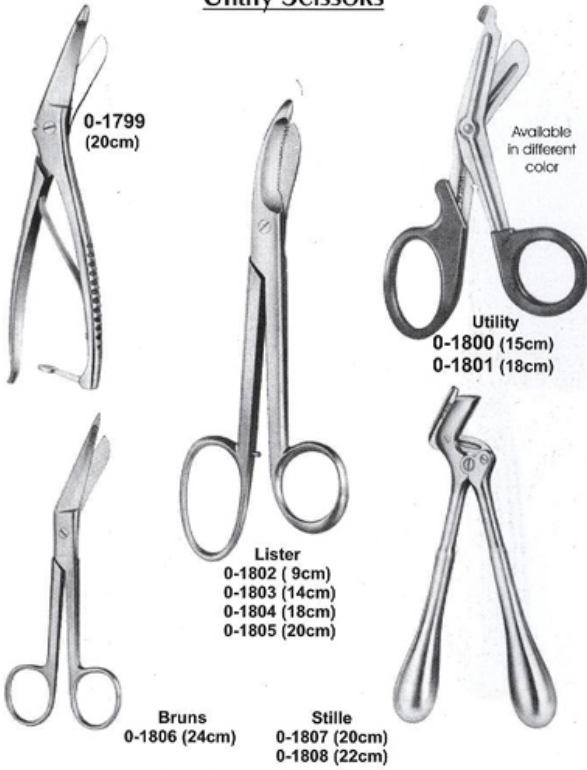

**PLASTER CAST INSTRUMENTS
PLASTER KNIVES, SAWS**

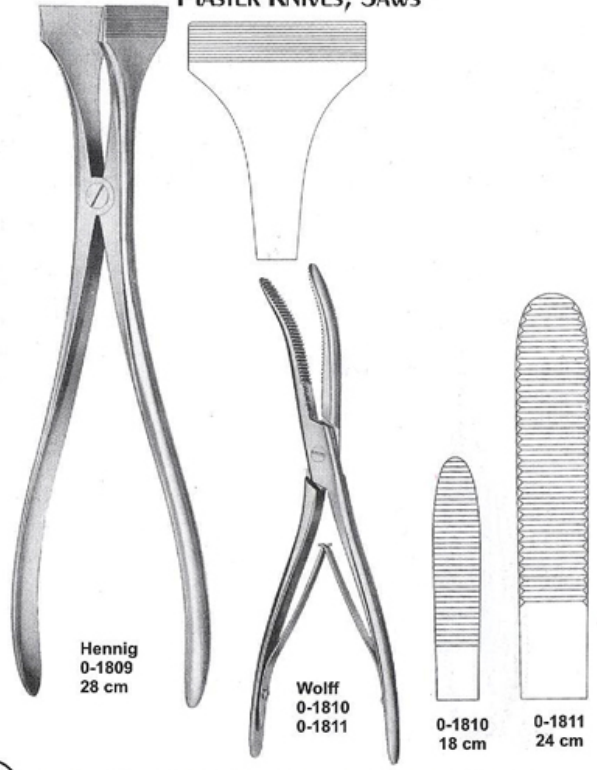

70

**BONE Holding Clamps
AMPUTATING & RESECTION SAWS**

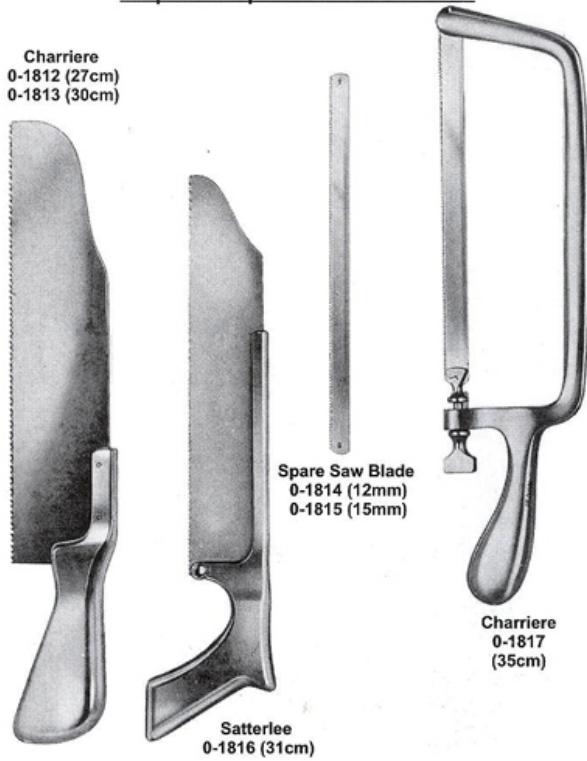

PLASTER CAST INSTRUMENTS, KNIVES, SAWS

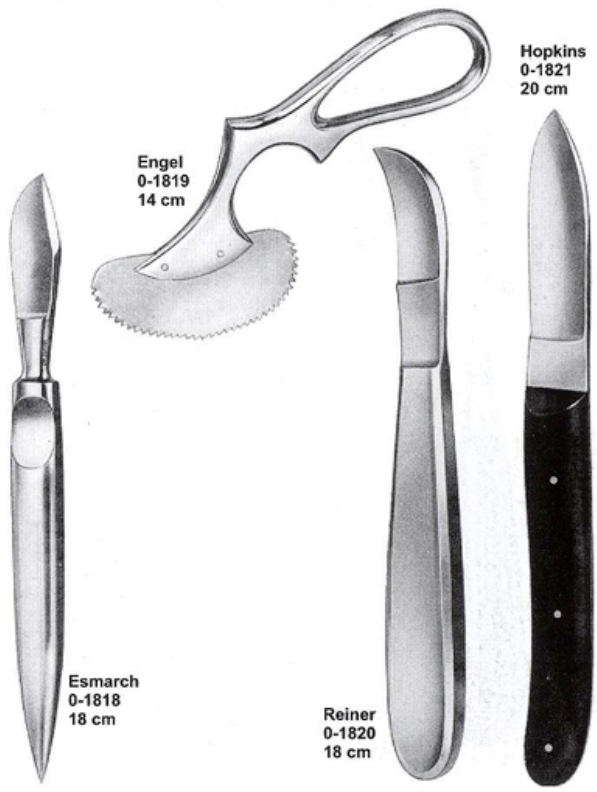

BONE HOLDING FORCEPS

BONE HOLDING FORCEPS



Farabeuf
0-1840
23cm/9"
0-1841
26cm/10½"

Farabeuf-Lambotte
0-1842
26cm/10½"

Tuffier
0-1843
27cm/10½"

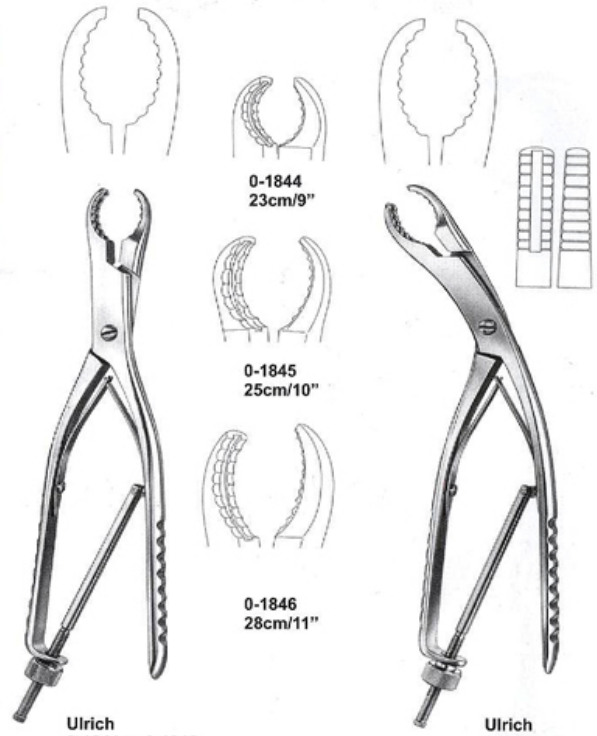

0-1844
23cm/9"

0-1845
25cm/10"

0-1846
28cm/11"

Ulrich
0-1844 to 0-1846

Ulrich
0-1847

BONE LEVERS

FLAT NOSE PLIERS

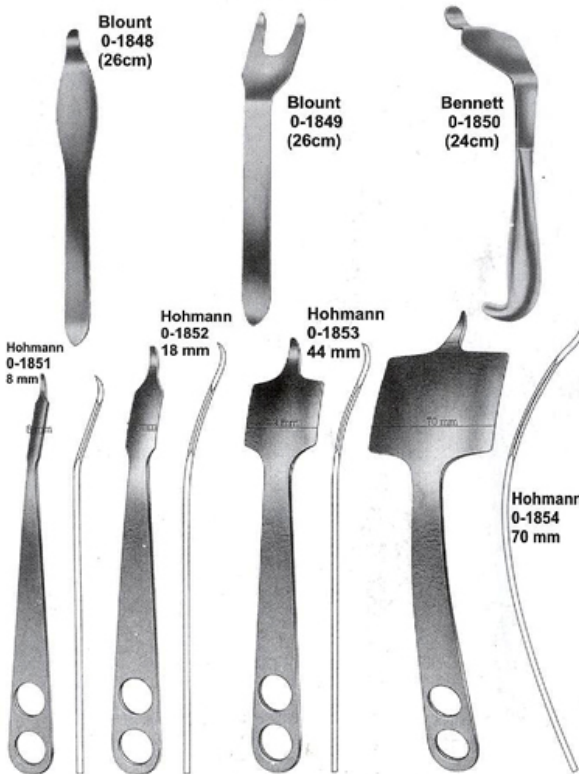

Blount
0-1848
(26cm)

Blount
0-1849
(26cm)

Bennett
0-1850
(24cm)

Hohmann
0-1851
8 mm

Hohmann
0-1852
18 mm

Hohmann
0-1853
44 mm

Hohmann
0-1854
70 mm



0-1855
16 cm / 6¼"

0-1856
to
0-1857
17 cm / 6¾"

0-1858
18 cm / 7"

BONE HOLDING FORCEPS

BONE HOLDING FORCEPS

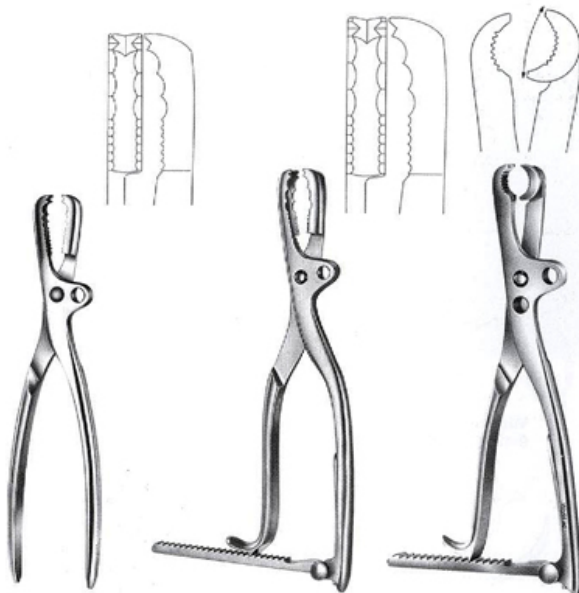

Farabeuf
0-1840
23cm/9"
0-1841
26cm/10½"

Farabeuf-Lambotte
0-1842
26cm/10½"

Tuffier
0-1843
27cm/10½"

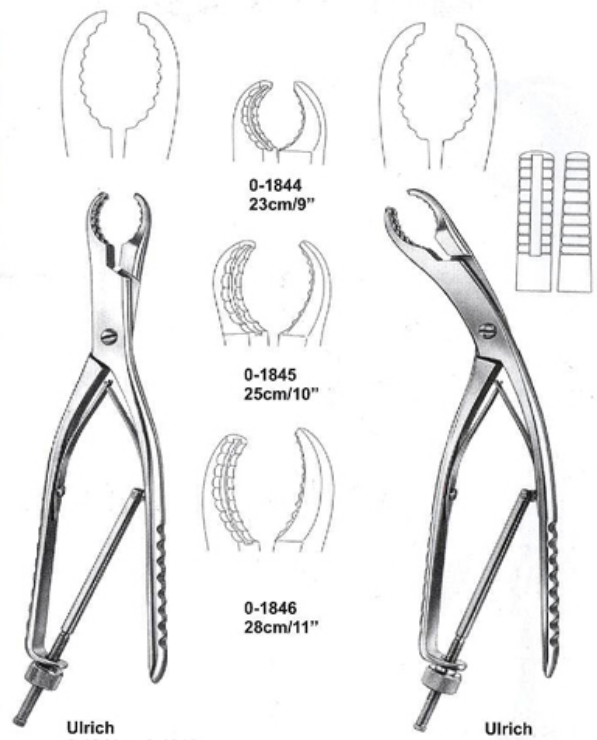

0-1844
23cm/9"

0-1845
25cm/10"

0-1846
28cm/11"

Ulrich
0-1844 to 0-1846

Ulrich
0-1847

BONE LEVERS

FLAT NOSE PLIERS

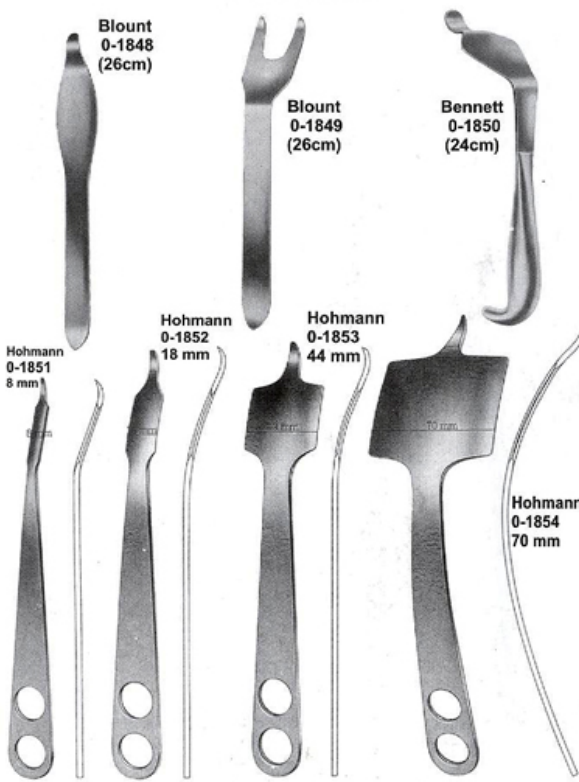

Blount
0-1848
(26cm)

Blount
0-1849
(26cm)

Bennett
0-1850
(24cm)

Hohmann
0-1851
8 mm

Hohmann
0-1852
18 mm

Hohmann
0-1853
44 mm

Hohmann
0-1854
70 mm



0-1855
16 cm / 6¼"

0-1856
to
0-1857
17 cm / 6¾"

0-1858
18 cm / 7"

BONE RONGEUR FORCEPS

0-1903 23 cm/9"
0-1904 27 cm/10½"



Stille-Luer
0-1903
to
0-1906

0-1905(23cm/9")
0-1906(27cm10½")

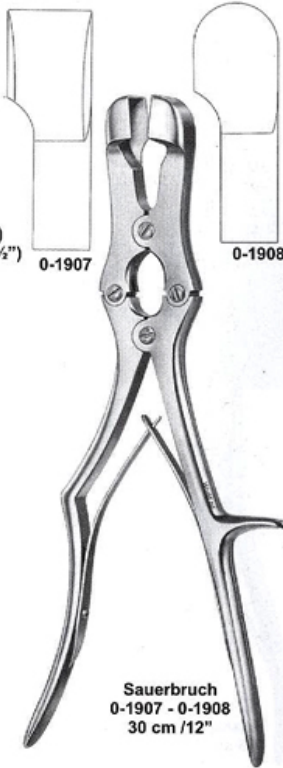

Sauerbruch
0-1907 - 0-1908
30 cm /12"

BONE CUTTING FORCEPS



0-1909 - 0-1910
15 cm /5¾"

0-1911
15 cm /5¾"

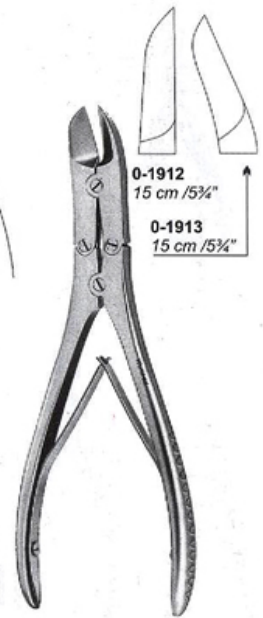

0-1912
15 cm /5¾"

0-1913
15 cm /5¾"

Ruskin-Liston
0-19121 - 0-1913
18,5 cm /7¼"

BONE CUTTING FORCEPS

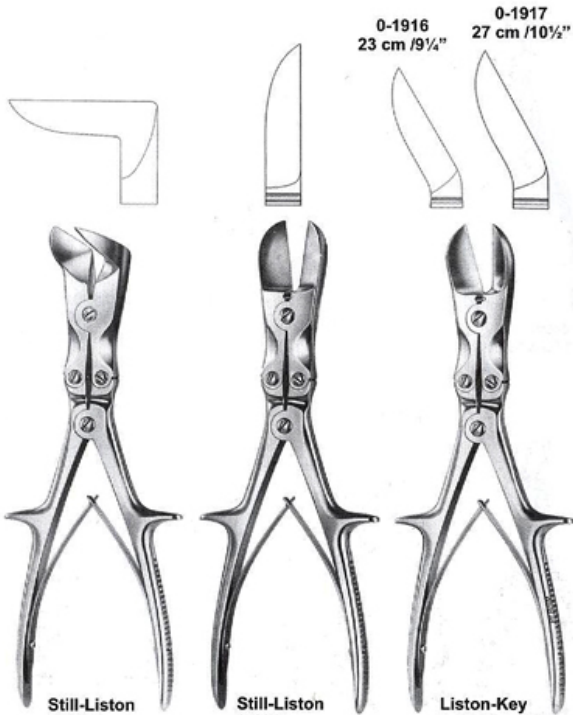

Still-Liston
0-1914
27 cm /10½"

Still-Liston
0-1915
27 cm /10½"

Liston-Key
0-1916 - 0-1917

0-1916
23 cm /9¼"

0-1917
27 cm /10½"



Cleveland
0-1918
17 cm /6¾"



0-1920
12 cm /4¾"

BONE CUTTING FORCEPS

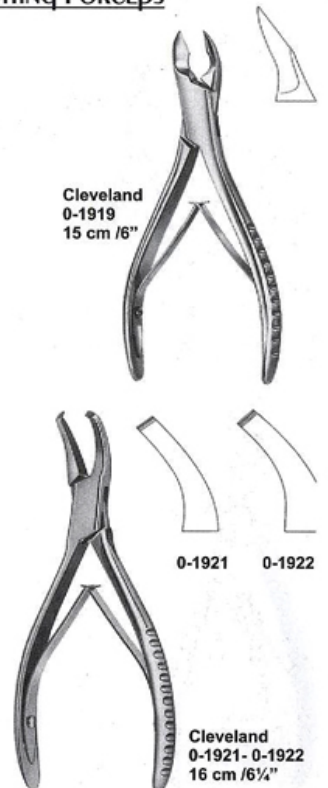

Cleveland
0-1919
15 cm /6"

0-1921 0-1922

Cleveland
0-1921 - 0-1922
16 cm /6¼"

BONE RONGEUR FORCEPS

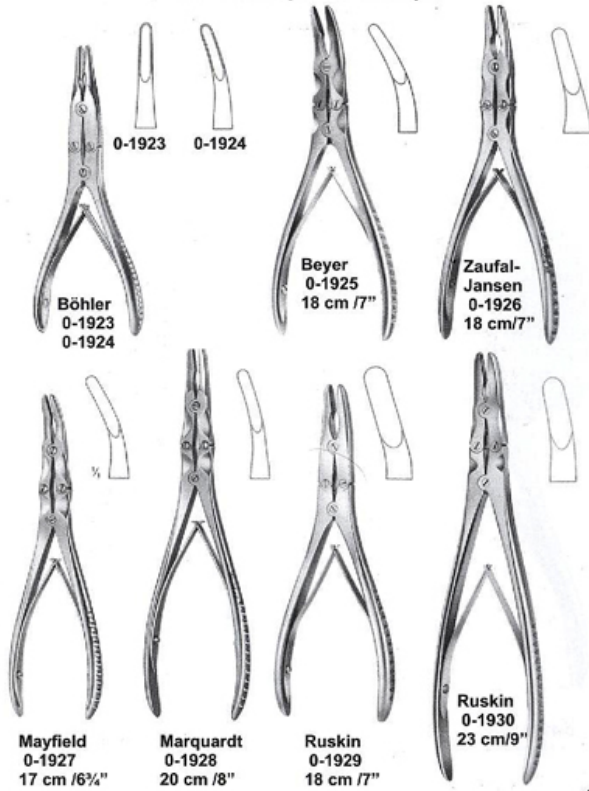

BONE RONGEUR FORCEPS

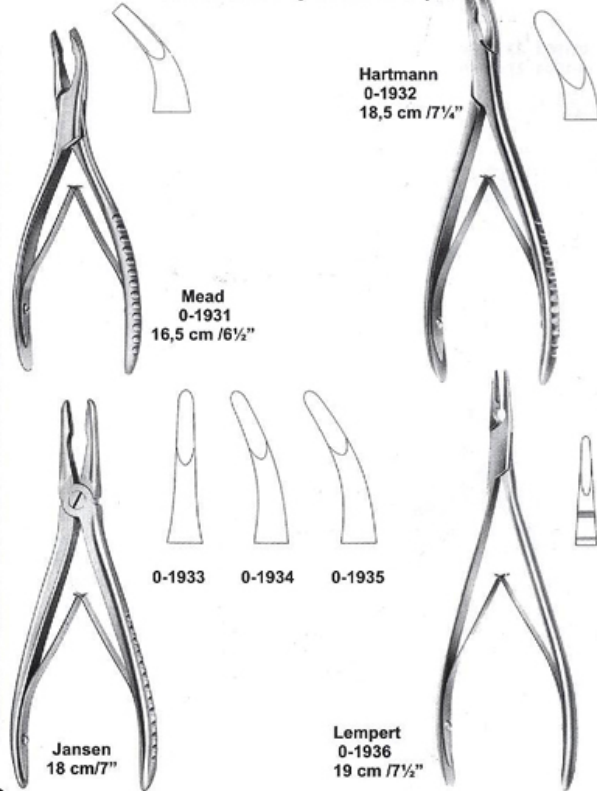

76

BONE RONGEUR FORCEPS

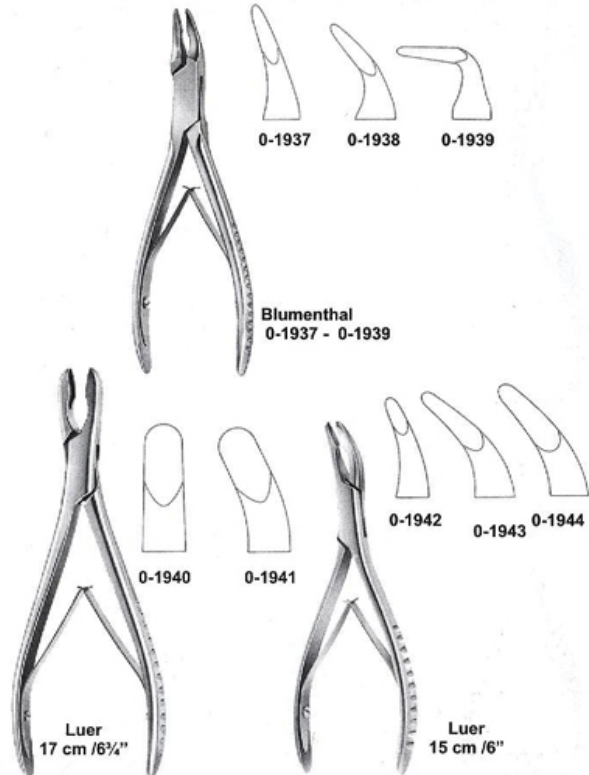

BONE RONGEUR FORCEPS

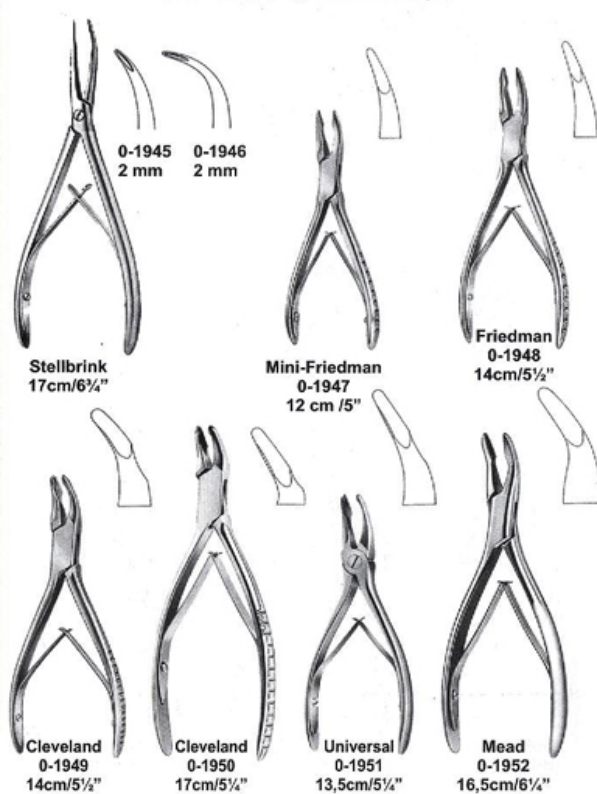

RASPATOIRES

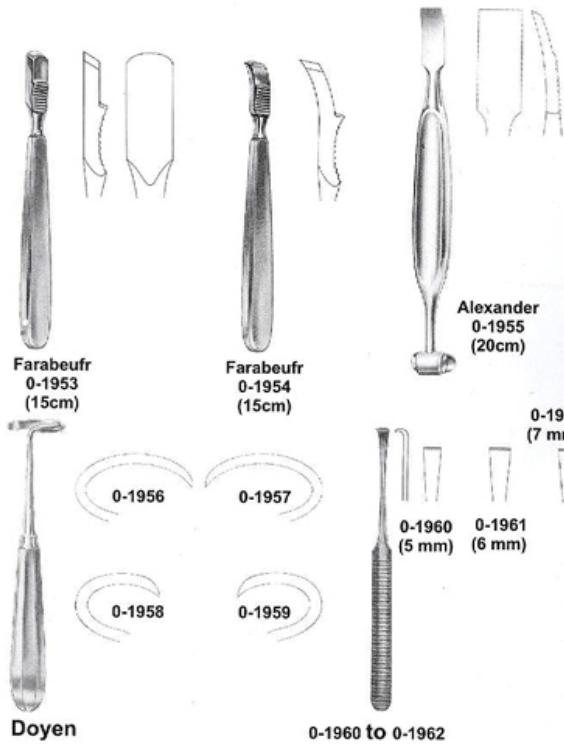

EXTENSION BOWS BONE WIRE TIGHTENERS

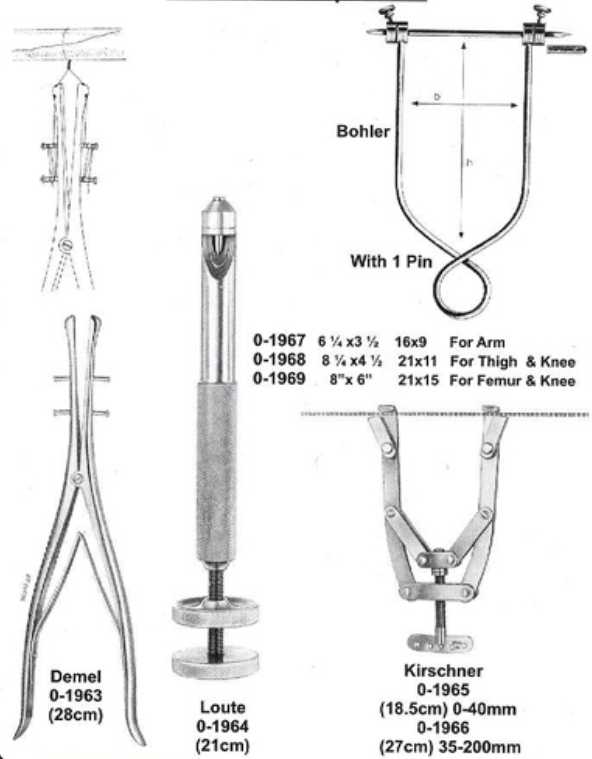

77

MALLETS



MALLETS, GOUGES & PERIOSTEAL ELEVATORS

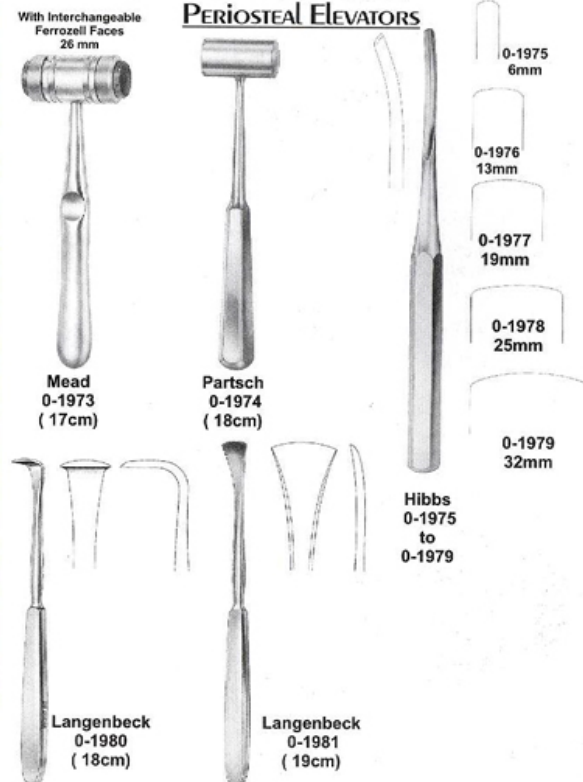

SURGICAL HOLLOWARE



Sterilizing Drums

0-1982	8x8 cm
0-1983	12x12 cm
0-1984	16x12 cm
0-1985	19x14 cm
0-1986	19x20 cm
0-1987	24x12 cm
0-1988	24x16 cm
0-1989	24x24 cm
0-1990	29x12 cm
0-1991	29x16 cm
0-1992	29x24 cm
0-1983	34x16 cm
0-1994	34x24 cm
0-1995	39x14 cm
0-1996	39x20 cm
0-1997	39x29 cm

SURGICAL HOLLOWARE



Wash Basin
0-1998
10 cm
12 cm
14 cm



Sponge Bowl
0-1999
12 cm
15 cm
20 cm

**Lotion Bowl
without spout / Lip**
0-2000
08 cm
10 cm
12 cm
14 cm
15 cm
20 cm
25 cm
30 cm
35 cm



SURGICAL HOLLOWARE

**Instruments Boiler with Lid
Perforated internal Tray & Hook**
0-2001
28x12.5x6.5 cm



Scaler Tray
0-2003
19x10x2 cm

**Instruments Box
Perforated**
0-2002
20x10x4 cm
24x15x4 cm
30x15x4 cm

SURGICAL HOLLOWARE

**Electric Sterilizer / Boiler
Hand Made**
0-2004



20x10x12 cm
25x12x14 cm
30x15x15 cm
35x17x17 cm
40x20x18 cm
45x23x19 cm

**Non Electric Sterilizer / Boiler
With Stand / Internal Tray**
0-2005

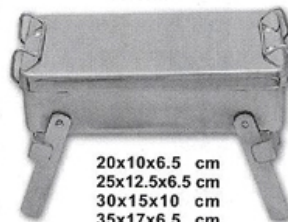

20x10x6.5 cm
25x12.5x6.5 cm
30x15x10 cm
35x17x6.5 cm
40x20x10 cm

SURGICAL HOLLOWARE



Instruments Tray
0-2006



Perforated Tray
0-2007
20x10x4 cm
25x12x5 cm
30x15x5 cm
35x17x5 cm
40x20x5 cm



Instruments Tray
0-2008
10x15x2.5 cm
15x20x4 cm
20x25x4.5 cm
25x30x5 cm
30x35x5 cm
15x30x5 cm
20x30x5 cm
23x15x5 cm



Mayo Tray
Utility Tray
Dental Tray
0-2009

SURGICAL HOLLOWARE



Instruments Box
with Cover & Hooks
0-2010
17x7x3 cm
18x8x4 cm
20x10x4 cm
23x12x5 cm
25x12.5x5 cm
30x15x5 cm
35x17x5 cm
40x20x9 cm
50x20x12 cm



Instruments Box
with Cover
0-2011

17x7x3 cm
18x8x4 cm
20x10x4 cm
23x12x5 cm
25x12.5x5 cm
30x15x5 cm
35x17x5 cm
40x20x9 cm
50x20x12 cm

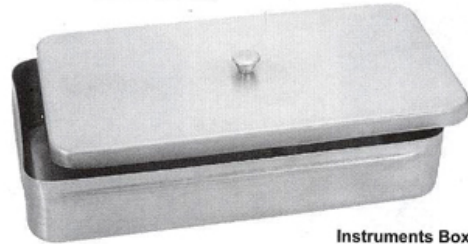

Instruments Box
with lid
0-2012

SURGICAL HOLLOWARE



Kidney Tray
with Lid
0-2013
15 cm
20 cm
25 cm
30 cm



Kidney Tray (Shallow)
0-2014
17 cm
22 cm
24 cm



Kidney Tray
(Traditional)
0-2015
12 cm
15 cm
18 cm
20 cm
25 cm
28 cm
30 cm

SURGICAL HOLLOWARE

Cather Tray
with lid
0-2016
30x8x4 cm
35x9x4.5 cm
40x10x5 cm

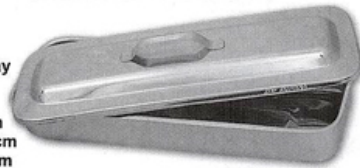

Instruments Tray
with lid
0-2017



10x15x2.5 cm
15x20x4 cm
20x25x4.5 cm
25x30x5 cm
30x35x5 cm
15x30x5 cm
20x30x5 cm
23x15x5 cm

Instruments Tray
With Lid
0-2018



SURGICAL HOLLOWARE



Dressing Jarr
0-2019
3X3 "
4X4 "
4 1/4 "X4 1/4 "
6X6 "

Dressing Jarr
0-2020
3X3 "
4X4 "
4 1/4 "X4 1/4 "
6X6 "



0-2021
Measuring Jug
0.25 Ltr
0.5 Ltr
1.0 Ltr
2.0 Ltr



0-2022
Enema Cane
Douch Cane / Irrigator



1.0 Ltr
1.5 Ltr
2.0 Ltr

0-2023
Enema Cane
Douch Cane / Irrigator

SURGICAL HOLLOWARE



Funnel
0-2024
125x127 mm

Kick Bucket With Trolley
0-2025
39x28x18 cm



SURGICAL HOLLOWARE



Bedpan Simple pressed Body
with handle)
0-2026 for Adult
0-2027 for Child



Bedpan Slipper Type
with Cover & handle
0-2028 for Adult
0-2029 for Child



0-2030
Bedpan Round
with cover & handle



Bedpan Hand Made
0-2031 for Adult
0-2032 for Child



All Products Are
Available In Different
Sizes

SURGICAL HOLLOWARE



Bedpan Perfection Type
(Seamless)
0-2033 for Adult
0-2034 for Child



Bedpan Perfection Type
0-2035 for Adult
0-2036 for Child



Urinal Male (Vertical)
0-2037

Urinal Female
0-2038

Urinal Male (Horizontal)
UNICEF
0-2039

SURGICAL HOLLOWARE



Cotton Holding Jar
0-2040

All
Products
Are
Available
In
Different
Sizes

5x18 cm
6.5x20 cm
8x20 cm
10x20 cm



Thermometer Jar
0-2041

0-2042
Forcep Jar

SURGICAL HOLLOWARE

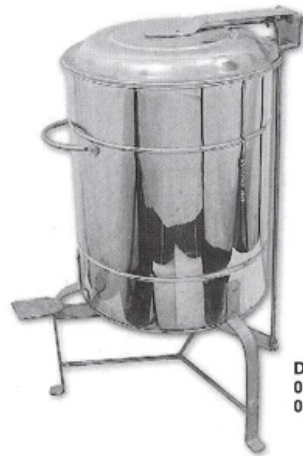

Dustbin with stand & Cap
0-2045 6.0 Liter
0-2046 10 Liter

81

SURGICAL HOLLOWARE



Needle Case Round
0-2047
8x2 cm

Needle Case Round
with cover
0-2048
6.5x1.5 mm

Needle Case Rectangle
0-2049
70x70x10 mm

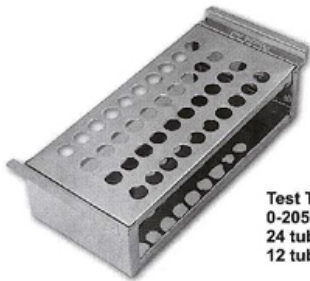

Test Tube Rack
0-2050
24 tubes
12 tubes

All
Products
Are
Available
In
Different
Sizes

SURGICAL HOLLOWARE

All
Products
Are
Available
In
Different
Sizes

Gallipots
0-2051
1 oz
to
16 oz

Gallipots with Lid
0-2052



0-2053
Spirit lamp
Double Knot
4 oz
6 oz



0-2054
Spirit lamp
4 oz
6 oz



Sputam Cup
Spitten Mug
0-2055 10x5 cm



Fetal Scope
0-2056 15 cm

Medicine Cup
Iodine Cup
0-2057
50/60/70 ml

